

Modernization Solutions





# CONTENTS

Electronics	03
Traction	25
Car / Counterweight Frame	33
Hydraulic	39
Doors	51
Interior Materials	63
Installation - Personal Protection	75
Mod Kits	87



# ELECTRONICS

# CONTROLLERS

## Genius20

### KLEEMANN GENIUS20 SPECIFICATONS

Number Of Stops	2-48
Speed (m/s)	Up to 3.0
Traction Manufacturer Compatibility	with most motors on the market
Type Of Valves Block	with most valves on the market
Call's Automation	All Options
Lift Automation	All Options
Standard	All Options
Safety Standards	All Options
Number Of COP (s)	Up to 2
Entrances Served	Up to 3
Car Door Compatibility	Automatic, Folding Bus
Short Flooring	300
Common DC	+ Positive
Voltage Of Button Panels (V)	24
Double Selective	Yes
Power Of Controller	Up To 55kw
Lift's Automation	All Options
Start-Up	All Options
Emergency Evacuation	All Options
Relevelling	All Options
Button Panels Direction Arrows	All Options
Fireman Service	All Options
Inverter Type	Zetadyn, STEP & FUJI FRENIC LM 2A



Your 100% KLEEMANN controller!  
An upgraded product,  
with 100% customisable software  
and a hardware designed  
to save up to 8 installation hours!

- Easier and faster installation
- Ability to apply new functions to suit specific customer need
- 8 hours of installation less
- Full training for all before the 1<sup>st</sup> installation
- Advanced connectivity with IoT solution (KLEEMANN Live)
- Effortless controller manipulation wirelessly through smartphone App (KLEEMANN Live Lift Control and Lift Control Pro)
- Destination Control System





# CONTROLLERS

## MRL DOORFRAME CONTROLLER CABINET (NARROW BOX)

This is a standard KLEEMANN product for MRL lifts where the controller cabinet is located in the door frame. For its use we have a prerequisite of a door frame width of at least 120mm. Inside the controller cabinet are placed only controller and inverter monitoring and programming tools, speed governor and brake release controls, intercom, power supply protection and light control. The main controller and the inverter are located in the shaft headroom in 2 separate boxes. In order to use this solution there has to be enough space inside the shaft headroom in order to fit those boxes.

Controller Cabinet		
W (mm)	H (mm)	D (mm)
120	2210 *	220

Cabinet placed in door frame inverter, resistance brake, additional controller material in headroom  
• For clear door height 2000mm

- 1. Inverter Box in the headroom
- 2. Controller Cabinet Doorframe or SCAN
- 3. Controller Box in the headroom



## MRL SCAN CONTROLLER CABINET (NARROW BOX)

This is a standard KLEEMANN product for MRL lifts where the controller cabinet is located in distance from the door frame. This controller box has a width of 150mm. Inside the controller cabinet are placed only controller and Inverter monitoring and programming tools, speed governor and brake release controls, intercom, power supply protection and light control. The main controller and the inverter are located in the shaft headroom in 2 separate boxes. In order to use this solution there has to be enough space inside the shaft headroom in order to fit those box.

Controller Cabinet		
W (mm)	H (mm)	D (mm)
150	2210*	220

Cabinet placed next to door inverter, resistance brake, additional controller material in headroom  
• For clear door height 2000mm



## ALL IN ONE (MRL)

This is a standard KLEEMANN product where the controller is located remotely from the door frame and all electronics including the inverter are inside. Controller cabinet dimensions are 460x300mm. Ideally, it fits to retrofit areas where top floor entrances cannot be amended, or where the customer prefers a wide working access.

Controller Cabinet		
W (mm)	H (mm)	D (mm)
460	2210*	300

- 1. Cabinet placed next to door frame
- MRL Ucontrol up to 11kw
- For clear door height 2000mm



### STANDARD MRL - 2 BOX CONTROLLER

This is a standard MRL product where the controller cabinet is located next to the door frame. The dimensions of the controller cabinet is 460x220mm.  
 - One additional Box in order to fit inside the inverter has to be placed in the Shaft Headroom.

2.

Controller Cabinet

W (mm)	H (mm)	D (mm)
460	2210 *	220



Cabinet placed next to door frame  
 • Typical MRL set up  
 • For clear door height 2000mm

3.

### SPECIAL DIMENSIONS CONTROLLER CABINET ALL IN ONE ( MR OPTION )

In case the MR entrance does not allow our standard controller boxes to pass through then we have a special solution. A MR with trapdoor entrance 500x400mm is no longer a problem. Also when the MR height is restricted a controller box can be fitted inside in most of the cases. If the controller has an inverter then it is placed in the same controller box. This solution is available just for the very small capacity inverter Fuji up to 11KW . For bigger capacity available in double box.

Controller Cabinet

W (mm)	H (mm)	D (mm)
460	1900	300

MR with trap door entrance size 500x400mm

- Hydraulic
- Traction AC2, VVVF Fuji up to 11KW

### STANDARD CONTROLLER CABINET ALL IN ONE ( MR OPTION )



4.

Used for almost all situations where the controller is situated in the machine room, whether hydraulic or traction application.

W (mm)	H (mm)	D (mm)
900	950	220
1100**	1500+100 BASE	400

- Traction Lifts AC1 / C2 / VVVF up to 22kw
- Hydraulic Lifts up to 77 KW
- VVVF Hydraulic up to 30 kW

\*\* Higher capacities would require a larger, customised cabinet to KLEEMANN engineering advise

### DOUBLE BOX CONTROLLER CABINET (MR OPTION)

Constructed as two separate controller boxes:  
 - One small to fit in the controller including all electronics, power supply modules and protection switches, safetys, programming tools , outputs to connect shaft and cabin cables.  
 - One additional to fit in the inverter.  
 Used mostly in high capacity MR Lifts. Both boxes should be placed inside the machinroom.

Controller Cabinet

W1 (mm)	H1 (mm)	D1 (mm)
750	1000	300
750	1200	300

- VVVF Hydraulic over Yaskawa 18,5KW-30KW
- Traction VVVF Fuji 29KW-45KW
- Traction 4CS inverter

### CUSTOMIZED MRL CABINET



5.

Upgrade the existing equipment with the new GENIUS20 electrical package. The GENIUS20 landing controller is re-designed to be installed in an existing cabinet, minimising the labor work on site. It is recommended to have the existing door operator replaced by the new KLEFER car door, to enhance performance. Additionally, the geared motor could be replaced by a high-end gearless motor. The new machine and controller package is compliant with the latest A3 UCM safety standards. Engineered solutions for a wide range of other MRL lifts.

1. Controller Cabinet All in one (MRL)
2. Controller Cabinet Standard (MRL)
3. Inverter Box in the headroom  
 The boxsize depends on the inverter capacity
4. Controller Cabinet All in one (MR)
5. Customized MRL Cabinet



# INVERTER

## Zetadyn 4CA

- Used with traction lift controllers ( Genius20 )
- MRL's & MR Traction lift with gearless & geared PM motors
- Dedicated product for 1:1 suspension
- Best ride quality, Direct approach ( DCP4 )
- Absolute best performance
- Zetadyn 4CA available for geared motors after special request

# INVERTER

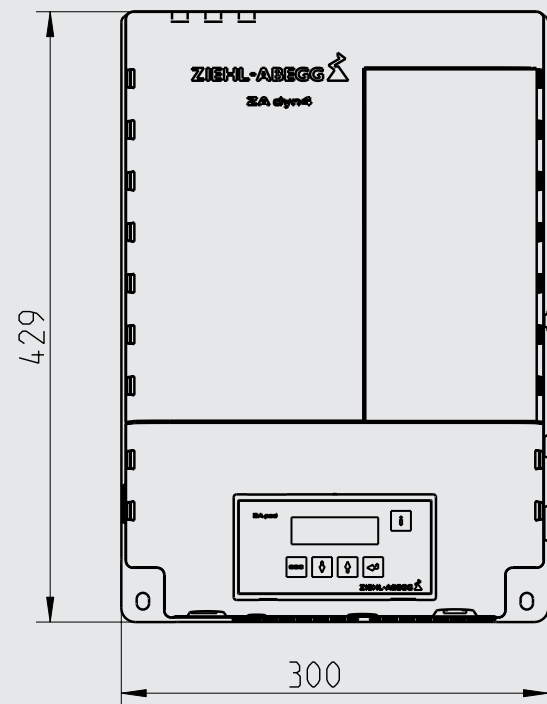

### ZETADYN ZADYN4C 011-032

- Wall installation in machine room or elevator shaft
- Mounting in the switch cabinet
- Line reactor & radio interference filter integrated
- Space-saving installation due to compact design
- Operation of synchronous motors (ZAdyn4CS) and asynchronous motors (ZAdyn4CA)
- Open-Loop-Operation of asynchronous motors
- Standby-function
- 4-line display with plain text display
- Minimal noise generation and low energy consumption through controlled ventilation
- Automatic travel curve pre-assignment
- Switching frequency: 4..16 kHz (automatic adaptation)
- Protection class: IP20

### ZETADYN ZADYN4C 040-074

#### INTERFACES

##### Controller

- Programmable inputs and outputs
- 5 x relay outputs (potential-free)
- 12 x digital inputs (24 VDC)
  - DCP
  - CANopen-Lift
- All interfaces galvanic isolated

##### Encoder

- Incremental encoder
  - HTL / TTL / Sinus
  - Absolute encoder
- EnDat / SSI / ERN 1387 / Codeface / Hyperface
- Encoder simulation for controller

##### Monitoring

- Temperature monitor brake resistor
- Temperature monitor motor (insulated input with electrically protective separation according to EN 61800-5-2)
- Motor contactor monitor (with optional use of motor contactors)
  - Brake release monitoring

The ZAdyn4C comes factory equipped with all interfaces

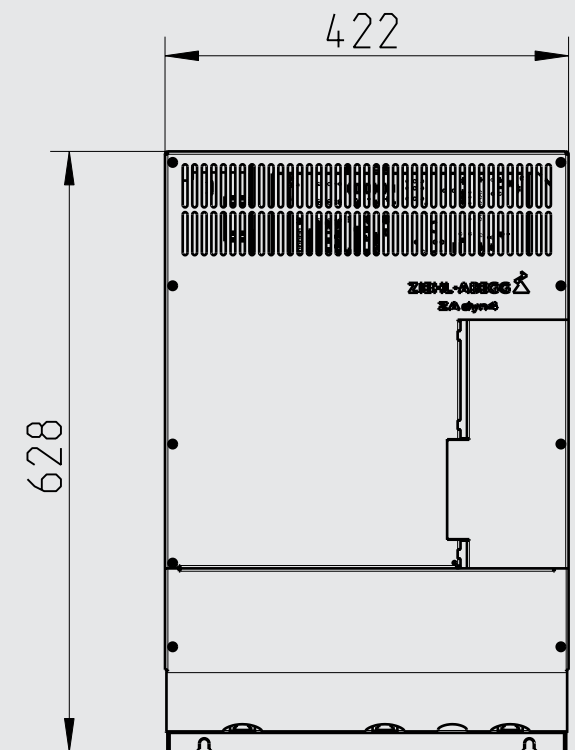

# INVERTER

## Fuji Frenic LM2A

- MRL's & MR Traction lift with gearless PM motors
- MRL's & MR Traction lift with geared VVVF induction motors
- MRL's & MR Traction lift with geared Open Loop induction motors
- Specially used for modernization
- Best Performance / Price ratio

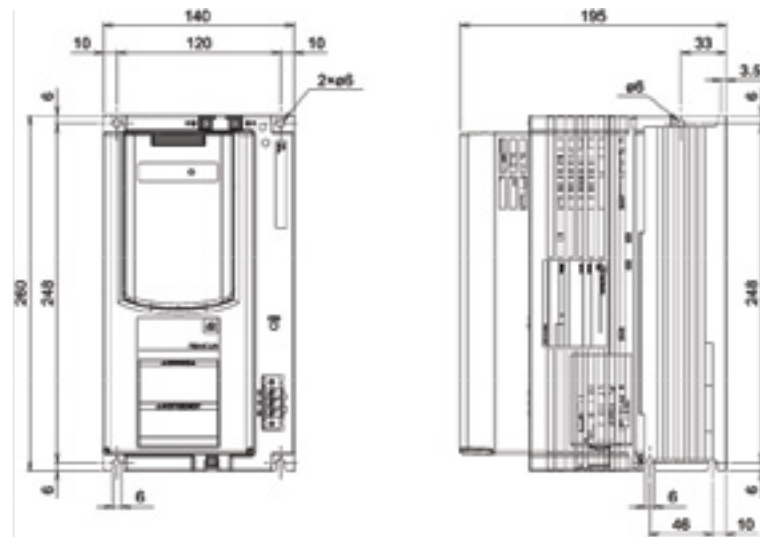

- STO function available -SIL 3 Certificate
- No motor contactors - Silent operation
- Built in EMC filter
- Power range 5,5kw - 45kw
- Compact aluminum braking resistors

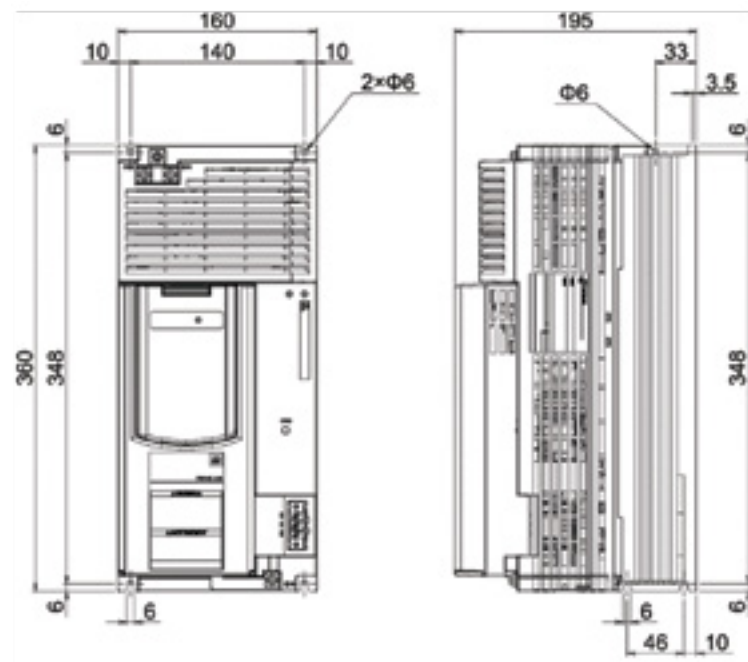

Three phase 400V series

Item		Specifications							
Type FRN__LM2A-4		0006	0010	0015	0019	0025	0032		
Nominal applied motor [kw]		2.2	4.0	5.5	7.5	11	15		
Output ratings	Rated capacity *1 [kVA]	4.6	7.6	11	14	18	24		
	Rated capacity *2 [V]	Three phase 380V-480V, 50/60Hz							
	Rated current *3 [A]	6.1	10.0	15.0	18.5	24.5	32.0		
	Overload capacity [A] (Permissible overload time)	11.0 (3s)	18.0 (3s)	27.0 (3s)	37.0 (3s)	49.0 (3s)	64.0 (3s)		
	Rated frequency [Hz]	50, 60 Hz							
Input ratings	Normal Operation	Phases, Voltage, Frequency	Three phase, 380 to 480 V, 50/60Hz						
		Variations	Voltage: +10 to -15% (Voltage unbalance: 2% or less *4) Frequency: +5 to -5%						
		Rated current *5 [A]	with CDR	4.5	7.5	10.6	14.4	21.1	28.8
			without CDR	8.2	13	17.3	23.2	33.0	43.8
	Main power supply	UPS Operation	Phases, Voltage, Frequency	Single phase, 220 to 480V, 50/60Hz					
			Variations	Voltage: +10 to -15%, Frequency: +5 to -5%					
			Operation time [s]	180					
	Battery Operation	Power supply voltage for driving	DC 48V or more in the direct current voltage conversion						
		Operation time [s]	180						
	Auxiliary control power supply Voltage		DC 24V (22V to 32V), Maximum 40W						
Braking	Braking Time *7 [s]		60						
	Braking duty cycle (%ED) *7 [%]		50						
	Rated regenerative power *7 [kW]		1.8	3.2	4.4	6.0	8.8	12	
	Minimum resistance which can be connected [Ω] *6		160	96	47	47	24	24	
EMC filter		Built in (According to EN12015, EN12016)							
Enclosure (IEC60529)		IP20							
Cooling method		Fan Cooling							
Average sound pressure level at trip. [dBA] *8		44.5	48	49.5					
Average power losses [W]		in standstill *12	23		26				
		in standby *13	16						
Weight [kg]		4.4	4.4	4.7	4.7	6.1	6.3		



# EMERGENCY EVACUATION SYSTEM

## RED – E

Automatic Evacuation Device only for geared motors.

Used with traction lift controllers (Genius 20)

During the evacuation process the main controller is replaced by the Emergency Evacuation system.

It is an independent controller dedicated to operate in case of a power failure. It makes use of all safeties

and operates the motor and door using its own power supply.

• Motor Voltage range ( variable voltages 290 - 400 VAC)

Brake voltage range ( can be adjusted according to motor need 48- 220VDC)

Doors ( VVVF doors & all kind of 3 phase door operators 125 - 380VAC)

Specialized for modernizations.



### BATTERY CHARGER

RED-R PWM is equipped with N° 1 double battery-charger 24+24VDC.

- Supply voltage : 1~230VAC 50Hz +8/-15%.
- Output voltage: 54.0VDC with load 0%
- RED-R PWM size 80 : N° 4 batteries 12V 12Ah
- RED-R PWB size 200 : N° 2 batteries 12V 18Ah

SMS recommends the use of dry fit, no maintenance batteries.

### PWM MAIN INVERTER

Main inverter:

- Battery Voltage: 48VDV.
- 3-phase Output Voltage: 15 ÷ 36VAC
- Output Frequency: 2 ÷ 10 Hz.
- Maximum Output Current (Peak):  
115 for RED-R PWM size 80, 370 for RED-R PWM size 200



Device / Code	Width (mm)	Height (mm)	Depth (mm)	Weight (kg) without batteries
RER0805.44.00	386	570	250	23
902.06.RR200	570	900	250	38

Device	SMS Code	Motor Power at 380/415VAC (both VVVF and 1 or 2 speed )	Advised Batteries
RED-R PWB Size 200	902.06.RR200	From 10kW to 100kW Nominal current from 20A to 200A	N.4 12V 18Ah
RED-R PWM Size 80	RER0805.44.00	From 17kW to 35 kW Nominal current from 15A to 50A	N.4 12V 12Ah

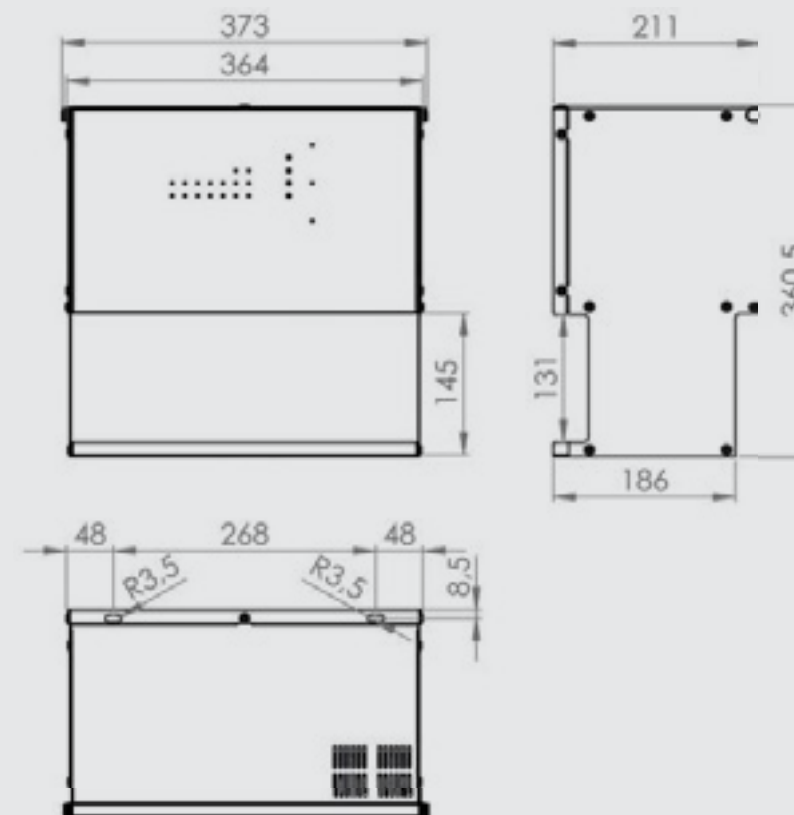

Device	Code	Motor	Width (mm)	Depth (mm)	Weight (kg)
RED E 18	REE018S.44.00	18A	366	210	18
RED E 35	REE035S.44.00	35A			

RED-E is equipped with a single board, which includes the following functions:

- Battery-charger, which can supply a 200mA current, with a 54VDC voltage, useful to charge n° 4 batteries 12V in series, up to 7Ah.
- The supply voltage for the battery-charger must be 230VAC 50/60Hz +/-10%• 3-Phase auxiliary inverter 3x36VAC 15A, which can supply the 2 transformers 200VA.
- The maximum output power is 600VA• 3-Phase power inverter PWM, with adjustable voltage from 18 to 36VAC.
- RED-E is protected against overload, polarity inversion of the batteries and output short-circuit, both for the auxiliary sections and the power section.
- RED-E is not protected against over voltage due to wrong connections on the motor output, or over supply (battery voltage higher than 60VDC).

# EMERGENCY EVACUATION SYSTEM

## Evac 3C

Automatic Evacuation Device only for gearless motors.  
Used with traction lift controllers (Genius 20)  
and inverter Zetadyn 4CS

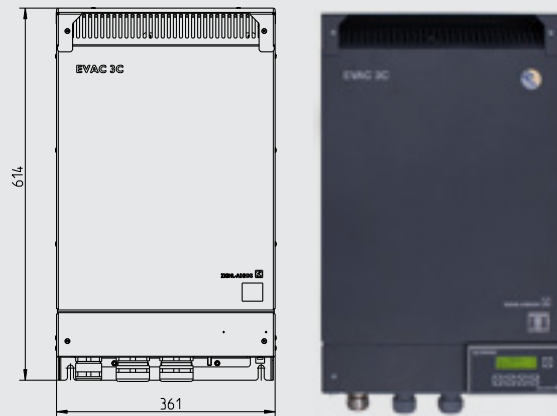

Technical data EVAC 3C

Electrical data	EVAC 3C032	EVAC 3C050	EVAC 3C074
Mains connection voltage [VAC]	3~360... 440 absolut		
Mains frequency (HZ)	50 / 60 (± 1,5 Hz)		
Battery voltage (VDC)	120 ... 180		
Battery type	Lead-acid rechargeable batter		
Heat dissipation [W]	< 20		
Power consumption / Charging mode [W]	max. 300		
Evacuation mode time limit (min)	20		
Ambient conditions			
Protection class	IP20		
Ambient conditions operation	55 from 40°C power reduction of 1.66% / 1K temperature increase		
Relative humidity (%)	90 / condensation prohibited		
Installation height (m above the sea)	Up to 2000		
Storage and shipping temperature	-20... +60		
Physical data			
Weight (kg)			
Dimensions w x h x d (mm)	361 x 614 x 197		
Max. protection fuse of the feeder inert (A)	35	50	80
Technical data power inverter			
Nominal power [W]	500		
Short	700		



# INCREMENTAL ENCODER

## Retrofit Kit for shaft encoder

Available only as spare part for modernization cases for geared motors.  
Its a product that transforms an old AC1 or AC2 motors and allow the effective  
operation by a VVVF traction lift controller.  
In addition it includes fixing materials. This solution offers the possibility to have  
the encoder remote form the motor shaft.

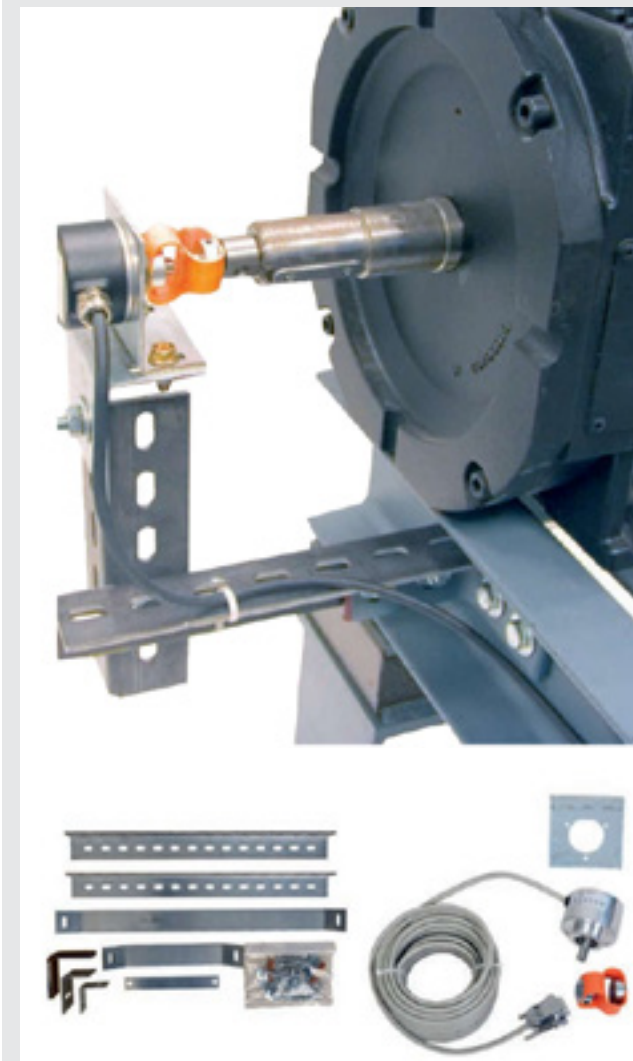

### ZA RETROFIT KIT

- Retrofit kit for fast and simple mounting of an incremental encoder with solid shaft
- Mounting with and without hand wheel possible
- Prefabricated encoder cable

### SCOPE OF DELIVERY

- Incremental encoder
- Incl. cable with plug D-SUB 15-pin for ZAdyn4C and ZETADYN 3
- Flex coupling
- Thermoplastic compensation element for connection between incremental encoder and motor shaft
- Adaptor for mounting the flex coupling on the motor shaft
- Motor add-on kit
- Solid angles and struts for rigid connection to the machine frame or floor



# INCREMENTAL ENCODER

## Ziehl Abegg

- For motor types VFD and other asynchronous motors
- Signal shape: sine or square
- Speed: Max 3500 rpm
- Phase shift: 90°
- With prefabricated connection cable
- Protection class: IP54



- Adaptor for quick and simple assembly of an incremental encoder with hollow shaft
- Assembly with or without handwheel

Type	Threaded nipple	Operating voltage incremental encoder VDC	Signal shape	Cable length m
Retrofit kit Incremental encoder	M8	4.75 .... 30	RS422 Inkremental	10.0
	M10			
	M12			
	M14			
	M16			
	M20			

Centring thread Motor shaft	Shaft diameter Adaptor mm	Order no.	Pos. 1	Handwheel 1x	Order no.	Adaptor to 28mm external diameter	2x Plate spring $\varnothing$ (external / internal)
M10	28	70024258	Pos. 2	Encoder 1X	70024258	M10	39.6mm / 25.5mm
M12		70024259	Pos. 3	Torque support 1x	70024259	M12	46.5mm / 30.5mm
M16		70024260	Pos. 4	Plate spring 2x	70024260	M16	51.5mm / 35.5mm
M20		70025581	Pos. 5	Adapter 1x	70025581	M20	51.5mm / 35.5mm

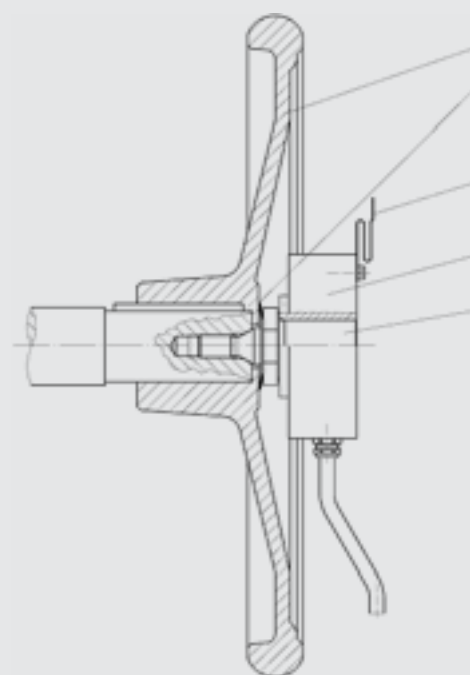

- Remove flywheel (if fitted)
- Locate the handwheel (pos.1) on the shaft up to the stop gauge
- Fit the plate springs (pos.4) with the smaller diameter on the adaptor (pos.5)
- Screw the adaptor (pos.5) into the center of the shaft.  
Pay attention: Cone must fit in shaft centering. Maximum concentricity difference of the adaptor:  $\pm 0,2\text{mm}$ .  
The plate springs (pos. 4) have to fit exactly on the stop gauge of the adaptor (pos.5)
- Locate the encoder (pos.2) on the adaptor (pos.5). Fix it with the two pin screws that are located on the encoder (see our installation instructions of an ET - encoder)
- It is necessary to provide a support on site for the torque support (pos.3)
- If the adaptor (pos.5) is installed without a handwheel, the plate springs (pos.4) and the handwheel (pos.1) are not required
- Attention: Depending on the mounting of the encoder, the tracks A and B or two phases of the motor have to be changed





# ABSOLUTE ENCODER

## Heidenhain ( Model ECN 1313 )

Mostly sold as a part of a new gearless motor.  
 Available also as spare part without cables.  
 For modernization purpose there is an option to supply it also with cables as a replacement for other defective or less advanced types of encoders, that need to be replaced and have the same mounting type. All Heidenhain encoders ECN/ERN 13xx can be replaced.



### ECN/ERN 1300 SERIES

Rotary encoders with integral bearings for elevator technology

- Simple installation
  - Rigid shaft coupling
  - Plane- surface coupling for large mounting tolerances
  - Uniform dimensions for various electrical interfaces
- Bearing of mating shaft
  - Bearing of encoder
  - Required mating dimensions
  - Measuring point for operating temperature
  - Screw plug, width A/F 3 and 4. Tightening torque: 5+0.5 Nm
  - PCB connector
  - Self-tightening screw M5 x 50 DIN 6912 width A/F 4, tightening torque 5+0.5 Nm
  - M10 back-off thread
  - M6 back-off thread
  - Max. permissible tolerance during motor shaft rotation  $\pm 1.5$  mm
  - Max. permissible static radial offset of motor shaft in indicated direction  $\pm 0.13$  mm
  - Direction of shaft rotation for output signals as per the interface description

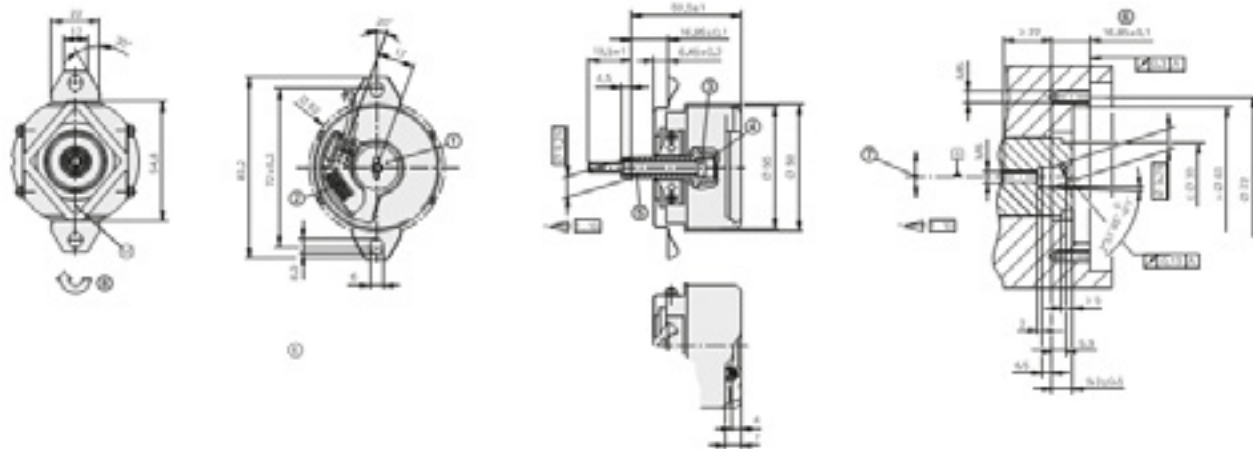

	ECN 1313
Part number	768295-xx
Interface	EnDat 2.2
Ordering designation	EnDat01
Position values/revolution	8192 (13 bits)
Electrically permissible speed/error	$\leq 1500$ rpm/ $\pm 1$ LSB $\leq 12\,000$ rpm/ $\pm 50$ LSB
Calculation time $t_{cal}$	$\leq 9$ $\mu$ s
Clock frequency	$\leq 2$ Mhz
Incremental signals	$\sim 1$ VPP
Line count/system accuracy	2048/ $\pm 20''$
Reference mark	-
Cutoff frequency -3 dB	$\geq 400$ kHz
Electrical connection	12-pin
Via PCB connector	
Voltage supply	DC 3.6V to 14 V
Power consumption (maximum)	3.6V: $\leq 600$ mW 14V: $\leq 700$ mW
Current consumption	5V: 85 mA (typical, without load)
Stator coupling	Plane-surface coupling
Shaft	Taper shaft $\varnothing 9.25$ mm; taper 1:10
Mech. permiss. speed n	$\leq 2000$ rpm
Starting torque	$\leq 0.01$ Nm (at 20 °C)
Moment of inertia of rotor	$2.6 \cdot 10^{-6}$ kgm <sup>2</sup>
Permissible axial motion of measured shaft	$\pm 1.5$ mm
Radial runout of the measured shaft	0.13 mm
Vibration 55 Hz to 2000 Hz	$\leq 300$ m/s <sup>26</sup> (EN 60 068-2-6)
Shock 6 ms	$\leq 2000$ m/s <sup>2</sup> (EN 60 068-2-27)
Operating temperature	-40 °C to +115 °C
Protection EN 60 529	IP40 when mounted
Mass	= 0.25 kg



# INCREMENTAL ENCODER



- Mostly sold as a part of a new geared motor.
- Available also as spare part.

## 1. NEMICON (MODEL SBH 1024 - 2T-30-050-00)

### External Dimension



### Electrical Specifications

Type		2T	2MT
Supply Voltage		DC 10.8 ~ 13.2 V	
Requirement		60 mA Max	
Output Voltage	"H"	Within -2.5 Power Supply Volt (VDC)	
	"L" *1	3 V Max	
Maximum Output Current		40 mA Max	
Rise & Fall Time		0.5 μs Max	
Maximum Frequency Response		150 kHz	

\*1) at Maximum Output Current

## 2. ELTRA (MODEL EH88 PE)

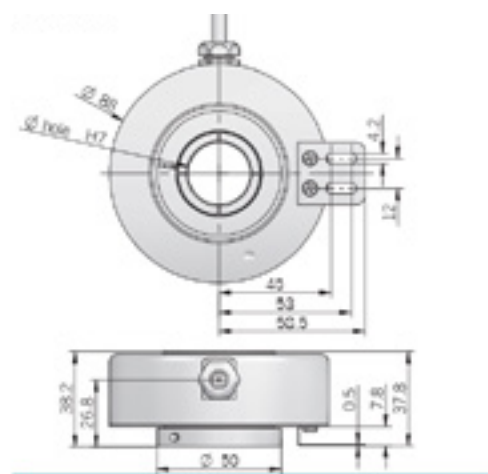

### Electrical Specifications

Resolution	From 500 to 2500 ppr
Power supply	5 = 4.5 ... 5.5 V DC
	5/28 = 4.75 ... 29.4 V DC
	8/24 = 7.6 ... 25.2 V DC (reverse polarity protection.)
Power draw without load	800 mW
Max load current	20 mA / channel
Output type*	Push-pull/ line driver
Max output frequency	105 kHz
Counting direction	A leads B clockwise (shaft view)
Electromagnetic compatibility	IEC 61000-6-2
	IEC 61000-6-3

\*Output levels according to power supply for further details please see under Technical basics section

- Cost effective encoder for asynchronous motors, suitable for elevators and stage machinery.
- 3 channel encoder (A/ B/ Z) up to 2500 ppr
- Power supply up to +28 VDC with several electronic interfaces available

- Up to 105 kHz output frequency
- Cable output, connector available on cable end
- Sturdy construction
- Up to 40 mm bore diameter
- Shaft fixing by collar clamping

## 3. LICA (MODEL : C80 )

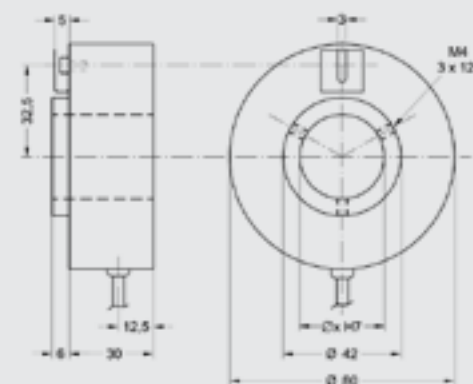

Available only as spare part for modernization cases for geared motors.

Its a product that transforms an old AC1 or AC2 motor and allows efficient operation by a VVVF traction controller. This kit adds an encoder to an existing AC1 or AC2 motor, replacing the existing heavy, metallic flywheel with a new low weight alternative.

### Electrical Specifications

STD pulse rate: (other PPR upon request)	12- 100- 200- 360- 400- 500- 1000- 1024- 2000- 2048 (2000 and 2048 without index pulse)
Power supply	+5V ± 5%, +10V +30V, +5V +30V
Output circuits	Push- Pull, Line Driver, PP/LD
Output current (per channel)	40 mA Max
Output frequency	100 kHz Max
Input current	70mA Max
Protection	Against inversion of polarity (except +5V version) Outputs are protected against short- circuit (except Line Driver version)
Optoelectronic life	100.000 hrs Min

## 4. WACHENDORF (MODEL WDG 115)

- Digital Tachogenerator with robust tacho flange
  - Up to 25000 PPR by use of high grad electronics
  - High noise immunity against frequency inverters
  - Protection to IP67, shaft sealed to IP65
  - 11 mm shaft
  - Full connection protection with 10 VDC up to 30 VDC
  - With light reserve warning
  - Optional: -40°C up to +80°C
- Protection to IP67 all around





# TRACTION

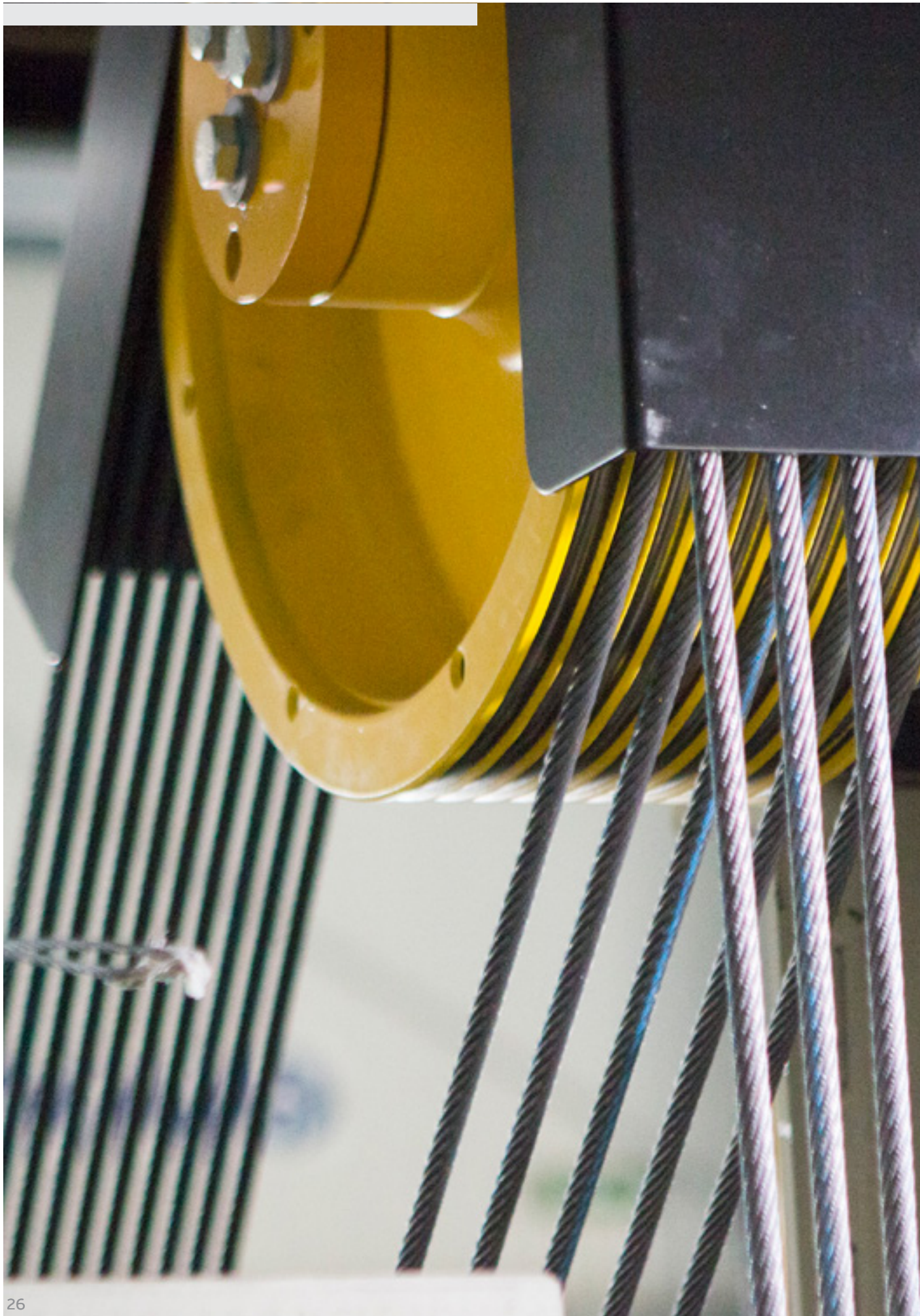



# TRACTION

## Machines

All type of motors

- Geared ( AC1\AC2\VVVF)
- Gearless

### SICOR SH110B

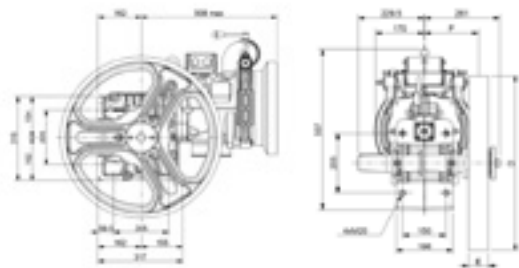

Wrappingsystem	Traction sheave		Dimension	Load*)	Static load direction
	D [mm]	E[mm]	P[mm]	F [kN-kg]	
CSW	320	76	190	20,6-2100	
	360	70	187		
	400				
	450				
	480				
	520				
	550				
600					

\*) Max. static load on the slow shaft:  
CSW: Conventional single wrap

### SICOR SH130B

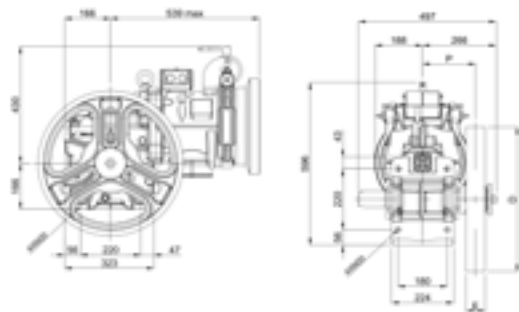

Wrapping system	Traction sheave		Dimension	Load*)	Static load direction
	D [mm]	E[mm]	P[mm]	F [kN-kg]	
CSW	320	76	195	25,5-2600	
	360	70	192	25,5-2600	
	400				
	450				
	480	70/90	192/197	25,5-2600/23,5-2400	
	520	70/90	192/197	25,5-2600/23,5-2400	
	550	70/90	192/197	25,5-2600/23,5-2400	
	600	70	192	25,5-2600	
	650				
700					

\*) Max. static load on the slow shaft:  
CSW: Conventional single wrap

### SICOR SH130BG

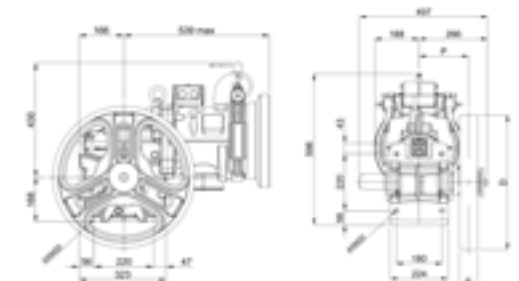

Winding system	Traction sheave		Dimension	Load*)	Static load direction
	D [mm]	E[mm]	P[mm]	F [kN-kg]	
CSW	480	90	197	28,4	
	520				
	550				

\*) Max. static load on the slow shaft:  
CSW: Conventional single wrap



ZIEHL- ABEGG

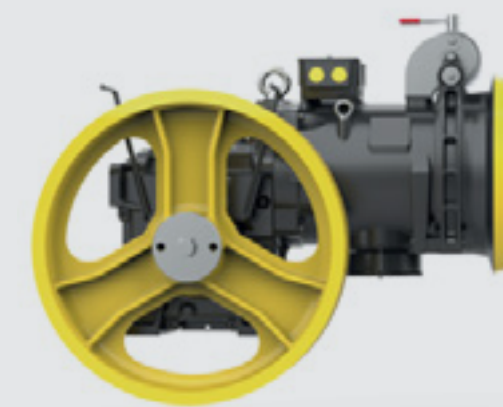

SICOR



LIFTEQUIP



ALBERTO SASSI



# TRACTION

## Machine base

Tailor made  
Variety of standard options  
Epoxy painted  
Split (optional)

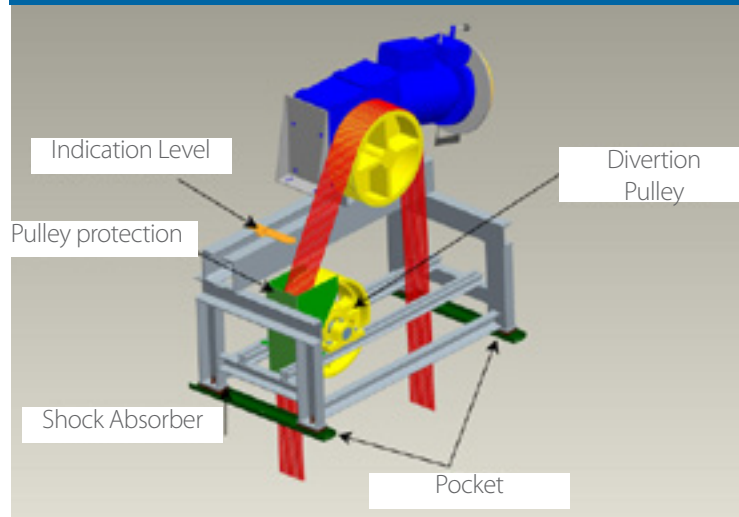

### STANDARD OPTION 1:1

- Diverting pulley
- Shock absorber
- Floor indicator
- Pocket
- Pulley bumper / protection
- Complete new base
- DBR up to 1000mm

### 2ND DIVERTING PULLEY

- Suitable for low headroom in machine room
- DBR above 1000mm

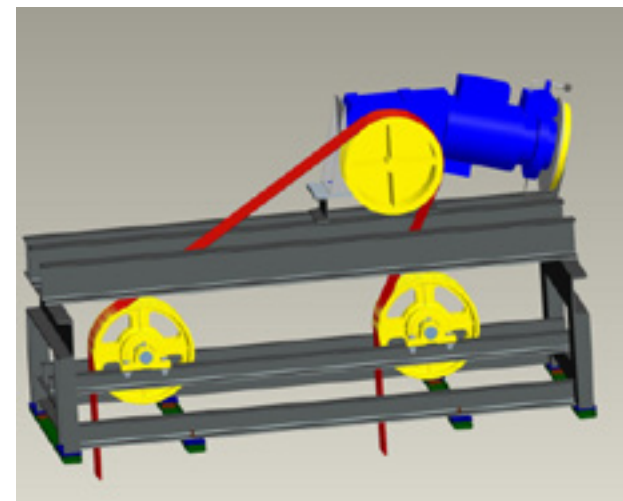

### MODERNIZATION TYPICAL BASE (CONCRETE)

- Machine room up
- Suitable for existing concrete base
- Acting 1:1, 2:1

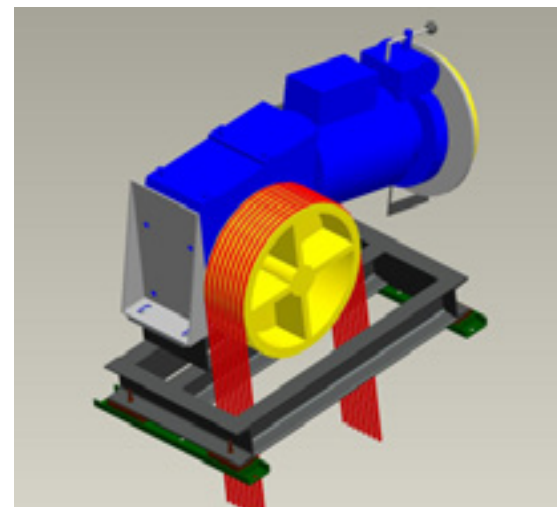

### MODERNIZATION TYPICAL BASE (METAL)

- Machine room up
- Suitable for existing metal base
- Acting 1:1

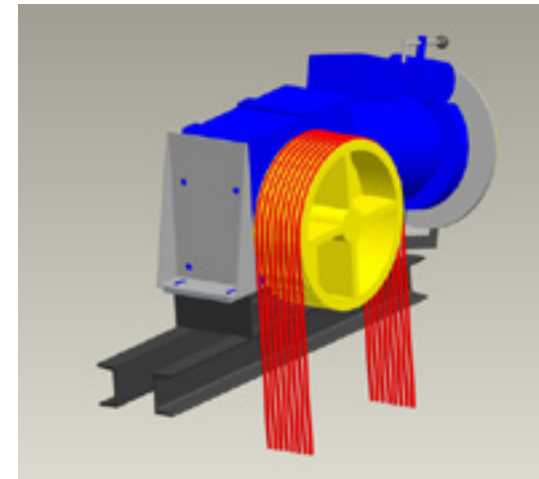

### MACHINEROOM DOWN

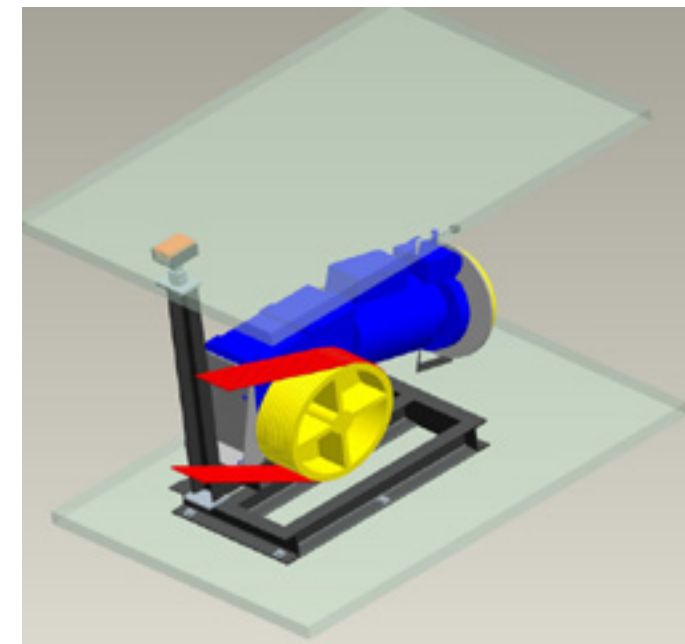

### ASSEMBLY MACHINE BASE (SMF)

- Ready to deliver
- DBR 570mm – 870mm

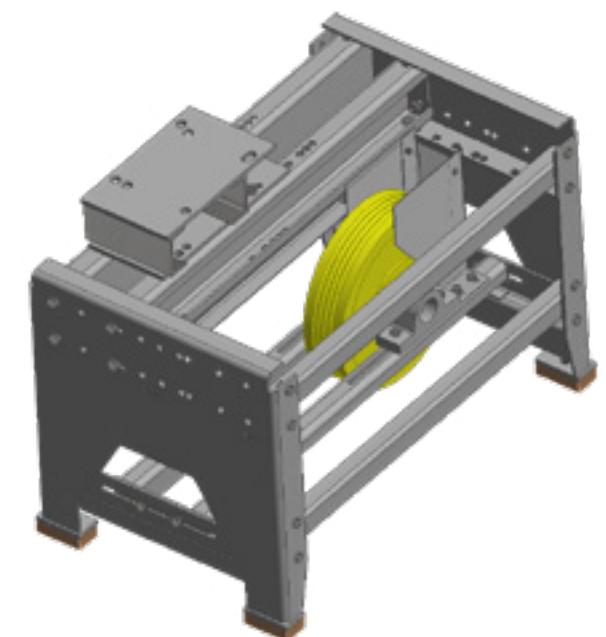



## TRACTION

# Hyper Frame

An additional assembly to be added to the car frame enabling the provision of bidirectional safety gear.

Thus, we can:

- Avoid uncontrolled overspeeding in up direction and
- Keep the existing car frame

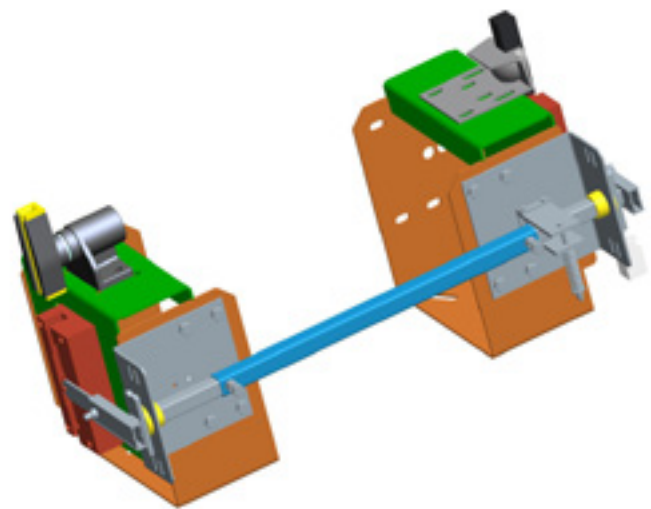

### SBFR1

Fitted on top of the car sling

**Max P+Q = 1300kg**  
**Dynatech PR2000UD / PR2500UD**  
**Max nominal speed 1.0 m/sec**

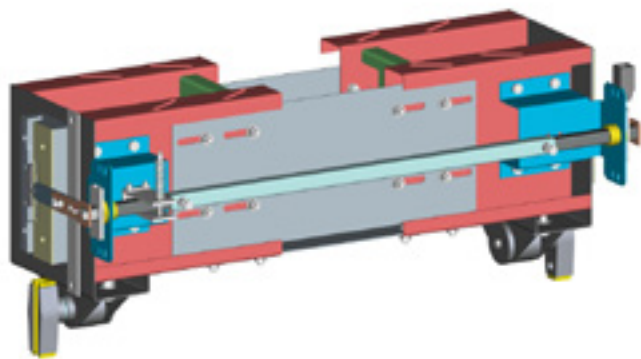

### SBFR2

Fitted below the car sling

**Max P + Q = 3500kg**  
**Dynatech PR2500UD / PR4000D**  
**Max nominal Speed 1 m/sec**

## TRACTION

# Rope Gripper

The Rope Gripper™ has many unique features, such as a gently applied but powerful 'grip' which doesn't damage the rope or cause any undue stress to the machine or traction sheave.

The Rope Gripper™ is mechanically activated and hydraulically reset, designed to provide safety breaking for uncontrolled movement when it is not possible to change the car safety gear.

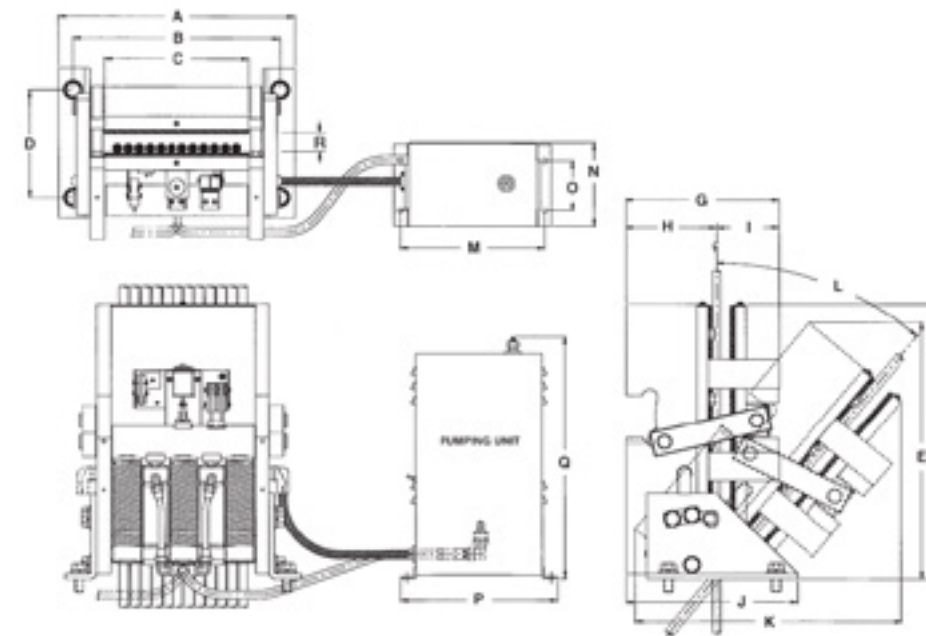

Dimensions

MODEL	A	B	C	D	E	F	G	H	I	J	K	L	M	N	O	P	Q	R
618	7 (178)	6 1/8 (156)	3 1/4 (83)	3 1/4 (83)	9 13/16 (249)	9 13/16 (249)	8 5/8 (219)	5 7/16 (138)	3 3/16 (81)	8 11/16 (221)	12 (305)	40°						1 1/4 (32)
620	10 1/8 (257)	8 5/8 (219)	4 7/8 (124)	5 1/2 (140)	11 11/16 (297)	12 (305)	9 1/4 (235)	5 3/4 (146)	3 1/2 (89)	9 1/2 (241)	13 1/2 (343)	45°	10 1/4 (260)	5 7/8 (149)	3 1/2 (89)	11 1/8 (283)	16 15/16 (430)	1 1/4 (32)
622	11 1/2 (292)	10 (254)	6 (152)	5 1/2 (140)	11 11/16 (373)	16 1/4 (413)	9 (229)	5 3/4 (146)	3 1/4 (83)	9 1/2 (241)	18 1/2 (419)	45°	10 1/4 (260)	5 7/8 (149)	3 1/2 (89)	11 1/8 (283)	16 15/16 (430)	1 1/4 (32)
624	16 1/2 (419)	14 1/2 (368)	10 (254)	7 1/2 (190)	17 7/8 (454)	19 (483)	10 3/4 (273)	6 3/8 (162)	4 3/8 (111)	12 (305)	18 9/16 (471)	40°	10 1/4 (260)	5 7/8 (149)	3 1/2 (89)	11 1/8 (283)	16 15/16 (430)	1 15/16 (49)
625	18 (457)	16 (406)	11 1/2 (292)	7 1/2 (190)	17 7/8 (454)	19 (483)	10 3/4 (273)	6 3/8 (162)	4 3/8 (111)	12 (305)	18 9/16 (471)	40°	10 1/4 (260)	5 7/8 (149)	3 1/2 (89)	11 1/8 (283)	16 15/16 (430)	1 15/16 (49)
626	16 1/2 (419)	14 1/2 (368)	10 (254)	7 1/2 (190)	17 7/8 (454)	19 1/4 (489)	10 3/4 (273)	6 3/8 (162)	4 3/8 (111)	12 (305)	18 9/16 (471)	40°	10 1/4 (260)	5 7/8 (149)	3 1/2 (89)	11 1/8 (283)	16 15/16 (430)	1 15/16 (49)



# CABIN / COUNTERWEIGHT FRAME



# CABIN / COUNTERWEIGHT FRAME

## Traction Cabin Frame

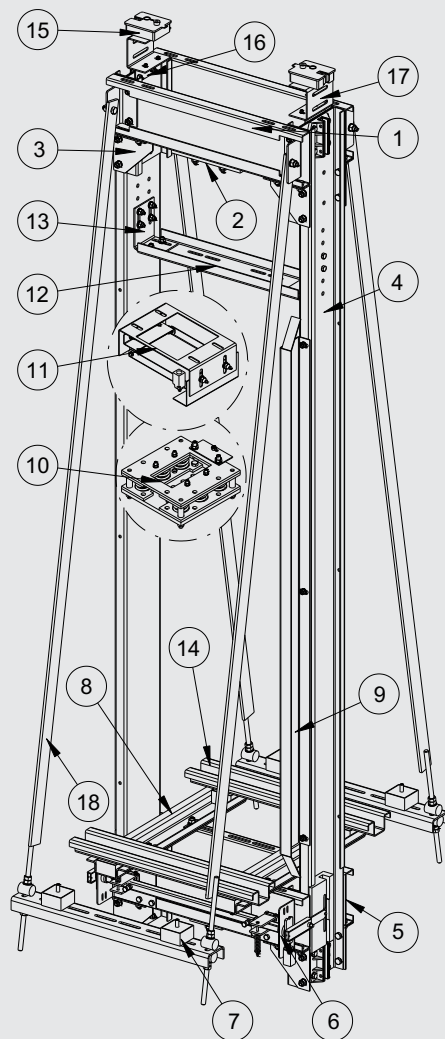

### TLCF 13-21

1. Upper beam
2. Rope suspension plate
3. Tie bar
4. Side frame beam
5. Lower beam
6. Safety gear
7. Elastic cabin base
8. Cabin support
9. Cam
10. Mechanical overload
11. Slack rope device
12. Upper cabin support beam
13. Cabin supports
14. Omega cabin support
15. Oiler
16. Base for oiler
17. Magnetic switch base
18. Cabin the bar

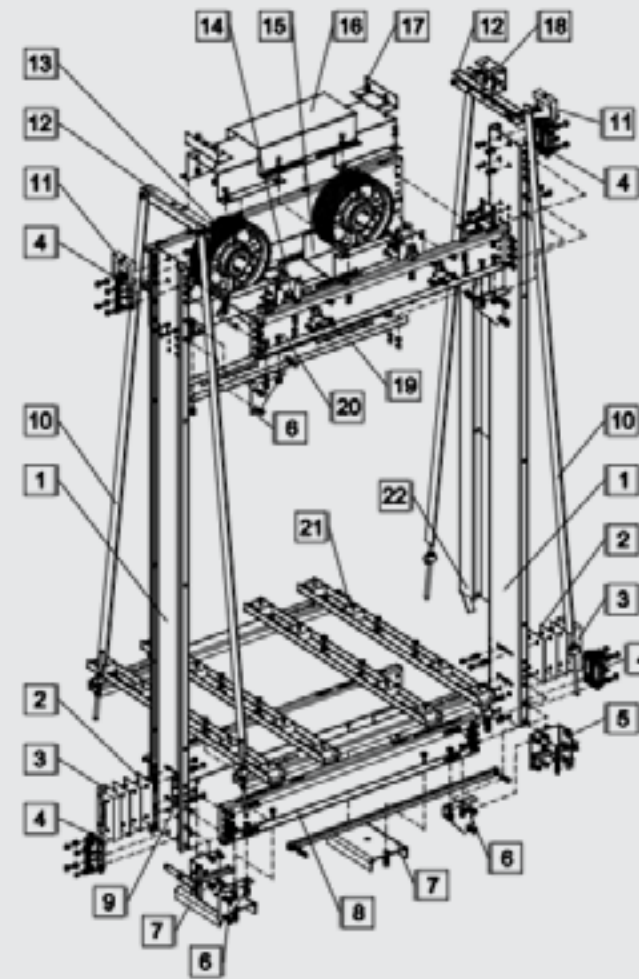

### TLCF 43 - 56

1. Side beam
2. Safety gear filler
3. Safety gear
4. Sliding shoe
5. Safety gear set
6. Strut
7. Buffer plate
8. Lower beam
9. Lower beam nut
10. Car strut
11. Oiler
12. Strut bracket
13. Pulley
14. Reinforced plate
15. Lower screen
16. Upper screen
17. Screen bracket
18. Sensor support
19. Cabin fixing bracket
20. Crosshead beam
21. Cabin platform
22. Switch cam
23. Safety gear's Supporting base



# CABIN / COUNTERWEIGHT FRAME

## Counterweight Frame

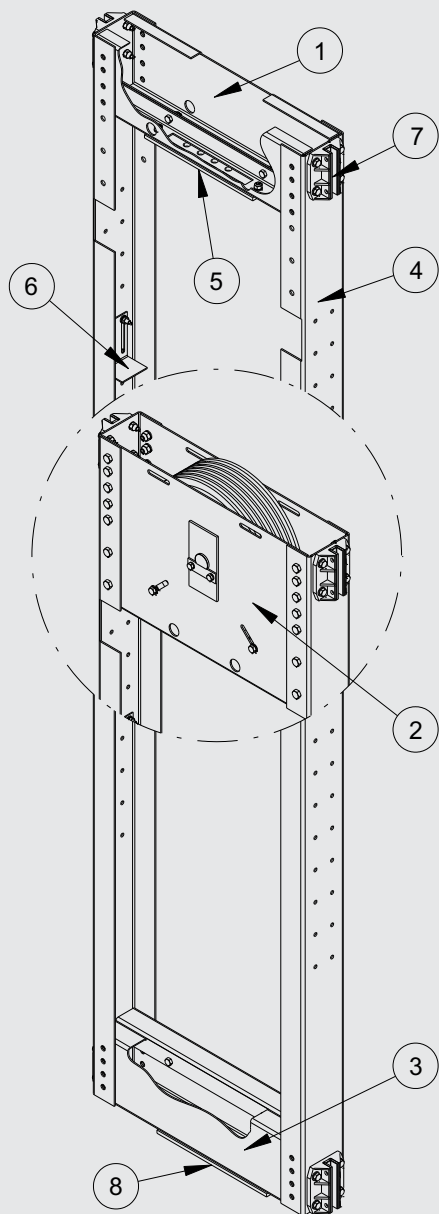

### CWF16 / CWF32

1. Upper beam
2. Upper beam 2:1
3. Lower beam
4. Side frame beam
5. Rope suspension plate
6. Counter weight safety
7. Slider
8. Buffet plate

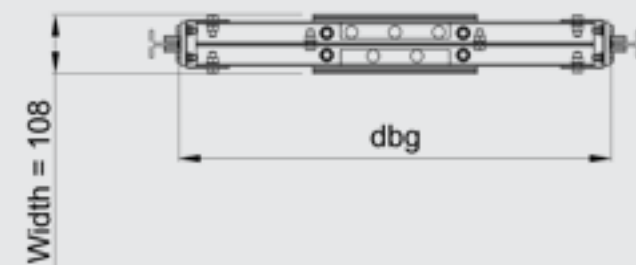
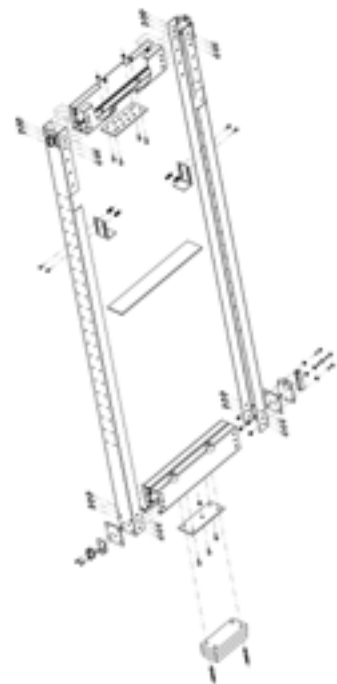

### TLCWF10

500mm ≤ dbg ≤ 900mm  
 P+Q/2=900Kg  
 Width: 108mm  
 Acting 1:1

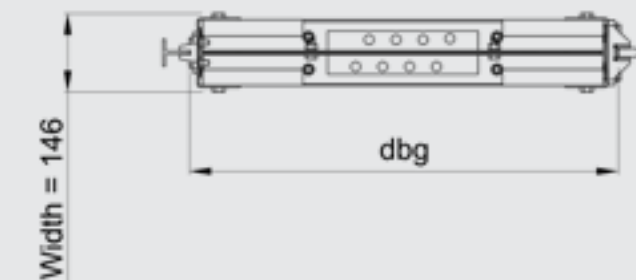

### TLCWF16

500mm ≤ dbg ≤ 900mm  
 P+Q/2=1600Kg  
 Width: 146mm  
 Acting 1:1, 2:1

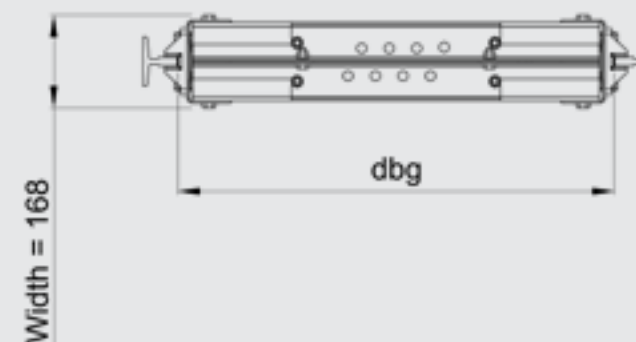

### TLCWF32

500mm ≤ dbg ≤ 900mm  
 P+Q/2=3200Kg  
 Width: 168mm  
 Acting 1:1, 2:1



# HYDRAULIC



# KLEEMANN HYDRO VVVF

## THE KLEEMANN HYDRO VVVF KIT

The ideal solution for both modernization projects and new installations. With a capacity of up to 90 trips per hour, it significantly enhances hydraulic lift performance, offering up to a 35% reduction in annual energy consumption, a longer equipment lifespan, and a smoother ride experience. It is compatible with all popular types of control panels and can be easily installed in just 2 hours.



## HOW IT'S USED

The KLEEMANN HYDRO VVVF Kit can be easily and quickly adapted to hydraulic lifts equipped a BLAIN EV100 valve. It connects directly to the control panel, and special components are fitted to the valve block.

With the use of this kit, the motor now operates with an inverter. This results in a significant reduction in energy consumption and a noticeable improvement in the ride quality, which becomes smoother.

## ADVANTAGES

### Maximum performance

The number of cycles performed by a hydraulic lift can now reach levels comparable to those of a traction lift, increasing from 30 to up to 90 cycles per hour, making it an ideal choice for demanding applications.

### Energy savings

The energy savings can reach up to 35% annually.

### Extended elevator lifespan

The energy savings can reach up to 35% annually. With Hydro VVVF, the operating temperature levels of the elevator are reduced, thereby increasing the lifespan of the hydraulic oil. Simultaneously, there is less mechanical wear on components, contributing to the extension of the motor's lifespan.

### Smoother ride quality

The movements are now smoother, resulting in significantly reduced mechanical wear on components.

### Power factor improvement

Reactive power is reduced, while the power factor (PF) is improved.

### Quick conversion

Installation is completed in just 2 hours, with only about 1 hour of downtime required for final adjustments.

### Compatibility

It is compatible with all popular types of control panels, providing flexibility both during installation and elevator maintenance.

### Noise Reduction

With HYDRO VVVF, elevator operating noise is reduced by up to 10 dB, creating a significantly quieter and more pleasant environment for passengers.

Whether it's an existing installation or a complete solution, the KLEEMANN HYDRO VVVF kit adapts perfectly to your needs.

## COMPONENTS

The KLEEMANN HYDRO VVVF Kit includes the cabinet with the inverter, as well as a range of special components for assembly on the valve.

### 1. INVERTER & CONTROLLER KIT



### 2. VALVE KIT COMPONENTS

For 3/4 "valve



For 1 1/2 "valve



## COMPLETE SOLUTION

The KLEEMANN HYDRO VVVF Kit offers a complete solution, including both the power unit and the GENIUS20 control panel.

### 1. INVERTER KLEEMANN HYDRO VVVF



### 2. GENIUS20 CONTROL PANEL



### 3. POWER UNIT (FROM 2.2 KW UP TO 55 KW)





# HYDRAULIC

## Power Unit

The power unit constitutes an integrated and efficient assembly, by means of which supply and flow control of the hydraulic oil to the lift unit is achieved. It consists of a metal frame, the motor-pump assembly (which is located within the metal frame), the block of valves (which is located on the top of the power unit) and the remaining hydraulic lift control systems.

# HYDRAULIC

## Cabin Frame

Acting 1:1, 2:1  
Tailor made

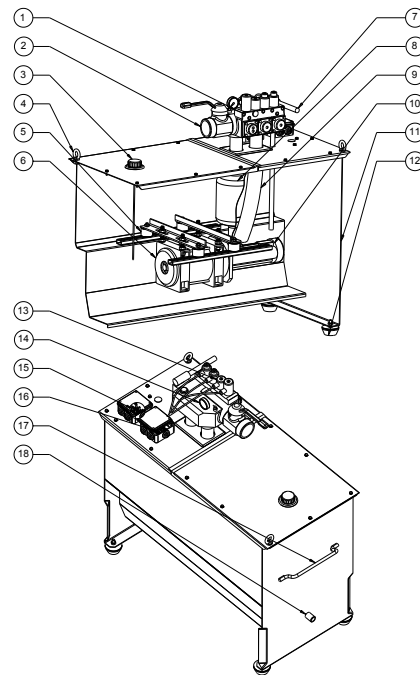
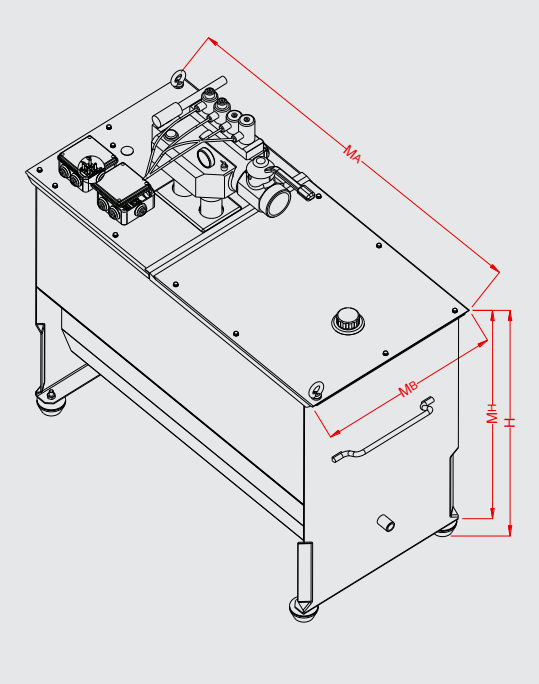

### POWER UNIT

1. Valve block
2. Supply ball valve
3. Tank plug- oil indicator
4. Suspension ring
5. Anti-vibration motor support
6. Motor
7. Hand pump
8. Silencer
9. Rubber hose return pipe
10. Pump
11. Metal oil tank
12. Anti-vibration tank base
13. Valve block solenoids
14. Pressure gauge
15. Power supply clamp
16. Valve block wiring clamp
17. Handle
18. Tank drainage nozzle

- Twin anchor areas
- Rollers / sliding shoes
- Adjustable to cabin height, dimensions
- Tailor made for DBG, guide rails
- Instantaneous / progressive safety gear
- Epoxy painted
- All types of acting (1:1 or 2:1, one or two pistons)
- Heavy duty use

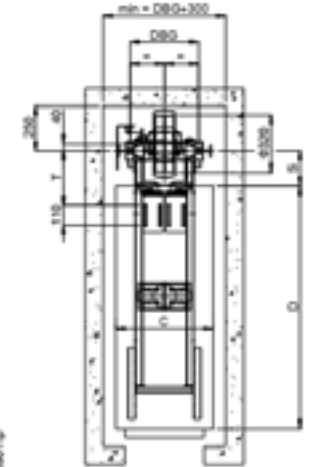
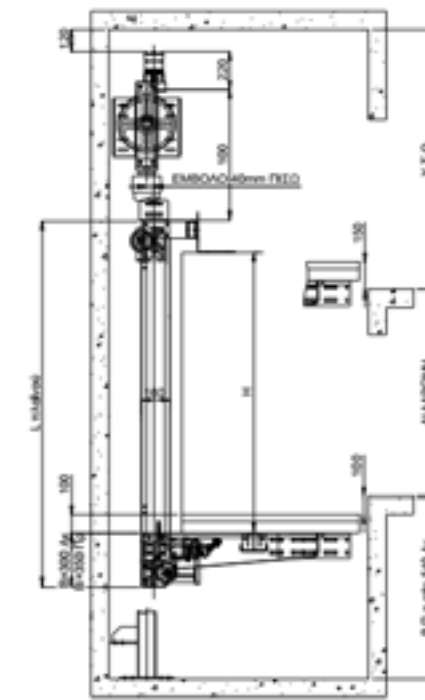
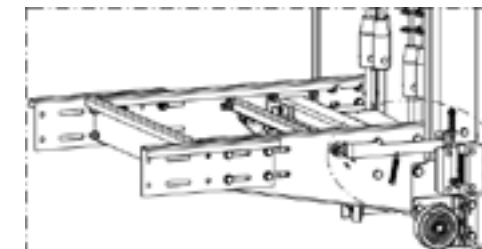

	(MA) (mm)	(MB) (mm)	(MH) (mm)	WEIGHT (Kg)	TOTAL VOLUME (Lit)	SERVICEABLE VOLUME (Lit)
T50	576	328	550	30	44	20
T150	821	516	705	52	127	55
T250	1072	516	790	64	206	110
T350	1072	516	990	75	305	207
T450	1323	516	990	87	385	260
T600	1323	630	1100	105	580	410
T750	1570	630	1100	128	700	500
T1200	1570	830	1245	245	1115	780
T80	610	320	686	32	80	38
T120	740	376	660	38	117	48
T250/NAR	1000	275	1000	50	216	145
T215/BL	900	430	780	67	223	142
T325/BL	900	430	1080	80	332	252
T190/PD	1400	415	605	90	185	95
T250/PD	1500	415	705	103	268	168
T350/PD	1600	415	805	118	350	243

The quantity of oil contained by the metal frame is sufficient to raise the lift unit while at the same time the motor and pump remain immersed in the oil.

# HYDRAULIC

## RAM

RAM Types are

- Simple (KZA, KZL, KZBC)
- Split (KZA-D, KZL-D, KZBC-D, KZT1-D)
- Double Split (KZA-DD, KZBC-DD, KZT1-DD)
- 2 – stage Telescopic
- 3 – stage Telescopic

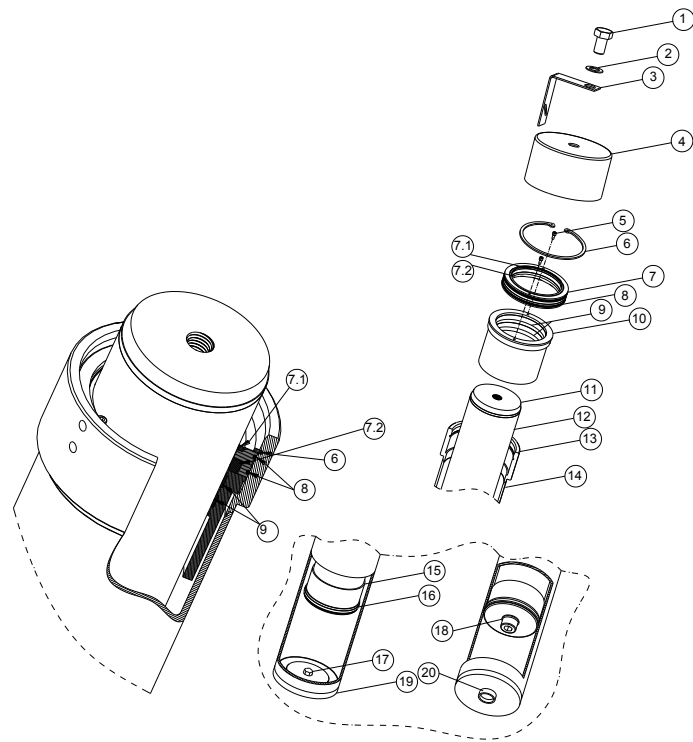

1. Hexagonal screw
2. Washer
3. Ram - safety blade piston
4. Plastic protective ram cover
5. Allen m6x8 screw
6. Retaining ring
7. Seal base
- 7.1. Wiper
- 7.2. Seal
8. O-ring
9. Bearing
10. Bearings base
11. Ram cover
12. Ram tube
13. Cylinder coupling
14. Cylinder tube
15. Damping rod
16. Ram bottom elastic ring
17. Hexagonal base
18. Allen screw m30x100
19. Cylinder bottom
20. Cylinder centering ring

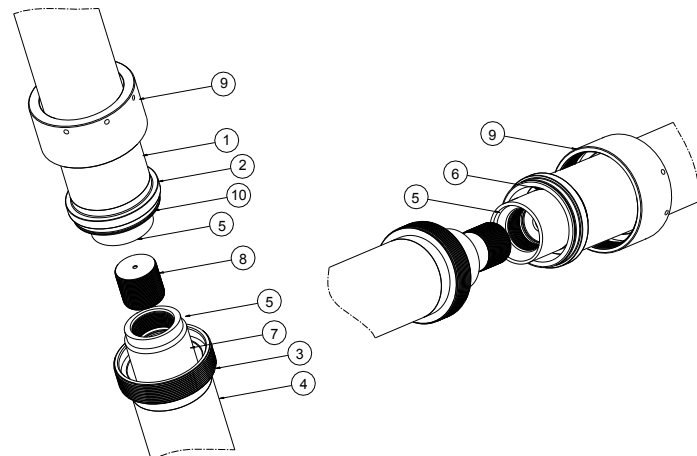

1. Upper cylinder tube
2. Split cylinder ring (upper)
3. Split cylinder ring (lower)
4. Lower cylinder tube
5. Split ram connection (upper, lower)
6. Upper ram tube
7. Lower ram tube
8. Connection screw of the ram division
9. Split screw nut
10. Split cylinder o-ring

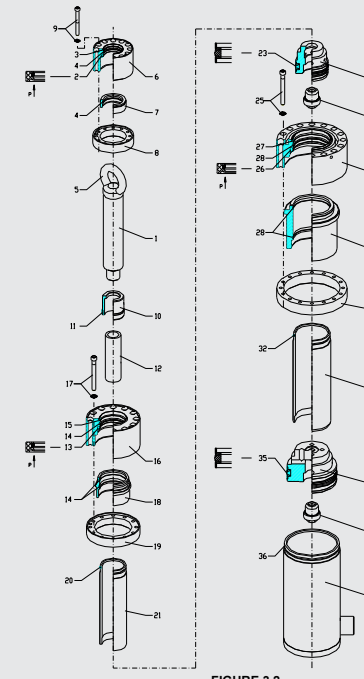
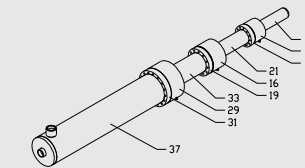

FIGURE 3.2



### 2 STAGE TELESCOPIC CYLINDER

1. Piston rod, 1st stage
2. Seal, 1st stage
3. Wiper, 1st stage
4. Guiding tape
5. Ring nut
6. Piston head, 1st stage
7. Guiding tape base, 1st stage
8. Fixing ring, 1st stage
9. Screw + spring washer, 1st stage
10. Damping rod, 1st stage
11. Guiding tape
12. Spacer, 1st stage
13. Seal, 2nd stage
14. Wiper, 2nd stage
15. Guiding tape
16. Piston head, 2nd stage
17. Screw + spring washer, 2nd stage
18. Guiding tape base, 2nd stage
19. Fixing ring, 2nd stage
20. O-ring
21. Piston tube, 2nd stage
22. Piston bottom, 2nd stage
23. Piston bottom seal, 2nd stage
24. Check valve
36. O-ring
37. Cylinder tube

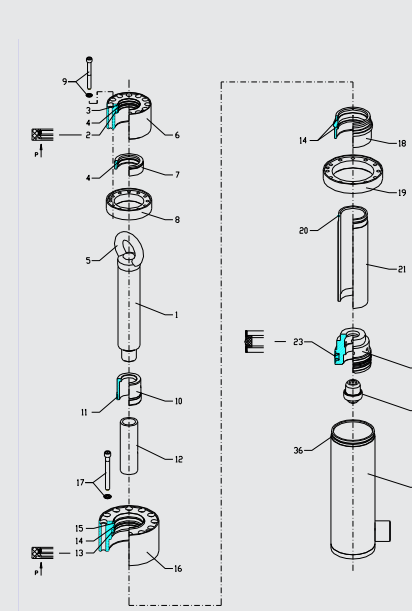
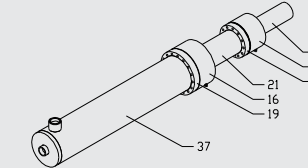

FIGURE 3.1



### 3 STAGE TELESCOPIC CYLINDER

1. Piston rod, 1st stage
2. Seal, 1st stage
3. Wiper, 1st stage
4. Guiding tape
5. Ring nut
6. Piston head, 1st stage
7. Guiding tape base, 1st stage
8. Fixing ring, 1st stage
9. Screw + spring washer, 1st stage
10. Damping rod, 1st stage
11. Guiding tape
12. Spacer, 1st stage
13. Seal, 2nd stage
14. Wiper, 2nd stage
15. Guiding tape
16. Piston head, 2nd stage
17. Screw + spring washer, 2nd stage
18. Guiding tape base, 2nd stage
19. Fixing ring, 2nd stage
20. O-ring
21. Piston tube, 2nd stage
22. Piston bottom, 2nd stage
23. Piston bottom seal, 2nd stage
24. Check valve
25. Screw + spring washer, 3rd stage
26. Seal, Guiding stage
27. Wiper, 3rd stage
28. Guiding tape
29. Piston head, 3rd stage
30. Guiding tape base, 3rd stage
31. Fixing ring, 3rd stage
32. O-ring
33. Piston tube, 3rd stage
34. Piston bottom, 3rd stage
35. Piston bottom seal, 3rd stage
36. O-ring
37. Cylinder tube



# HYDRAULIC

## Oil cooler

Reduces faults relating to high oil temperature such as:

- Shorten lifespan of sealing parts and oil
- Deteriorated level stopping accuracy
- UCM fault triggering

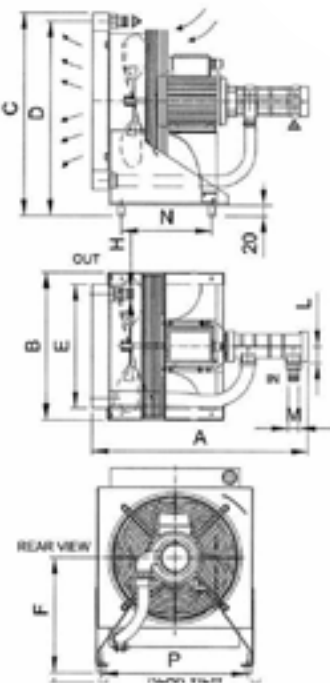

◀ NEG06  
NEG10  
NEG20

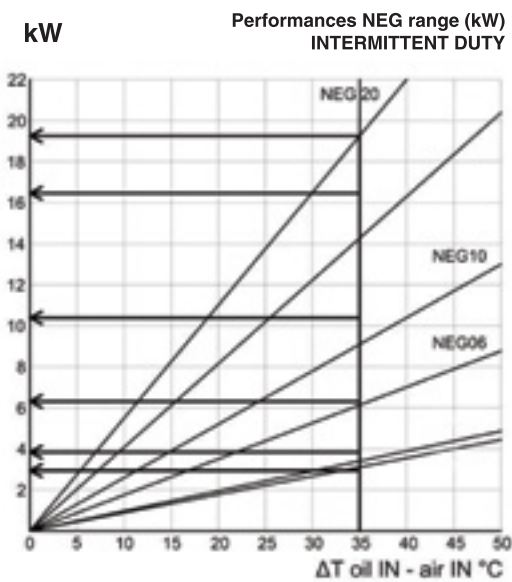

The values indicated in the diagram refer to hydraulic oil with a kinematic viscosity of 32 cSt at 40°C and an ambient temperature during testing of 20°C.

Dimensional Chart (mm)

SIZE	Kcal/h T 35°C at 20°C ambient	A	B	C	D	E	F	H	L	M
NEG#06	6000 (7)	578	410	536	513	335	303	1" GAS	44	1" GAS
NEG#10	9000 (10,5)	578	410	536	513	335	303	1" GAS	44	1" GAS
NEG#20	16500	637	536	695	675	475	340	1" GAS	44	1 1/4" GAS

### Operating features

		NEG#06		NEG#10		NEG#20	
		50 Hz	60 Hz	50 Hz	60 Hz	50 Hz	60 Hz
Dispersion when dT = 35 °C(ambient temperature 20°C)	kW	6,98		10,5		19,2	
	kCal/h	6000		9000		16500	
	BTU	23810		35550		65556	
Pump flow rate		30	36	38	45,5	85	100
		7,9	9,5	10	12	22,5	26,5
Fan capacity	m3/h	1300		1300		2500	
	CFM	764		764		1471	
Running speed		50 Hz	60 Hz	50 Hz	60 Hz	50 Hz	60 Hz
	giri RPM	1450	1750	1500	1800	1450	1750
Average noise level	dB(A)	68		68		71	
Weight	DaN	35		35		55	
	LBS	77		77		121	
MIN-MAX oil temp	°C	20-70		20-70		20-70	
	°F	68-150		68-150		68-150	
Max admitted pressure	bar	4		4		4	
	PSI	58		58		58	
Required NpsH	bar	-0,4		-0,4		-0,4	
	PSI	-5,8		-5,8		-5,8	

# HYDRAULIC

## Box Lift

Double space cabinet for both power unit and controller.  
Used in Hydraulic MRL's. It has inside plenty space to fit also an Hyrdaulic VVVF controller.

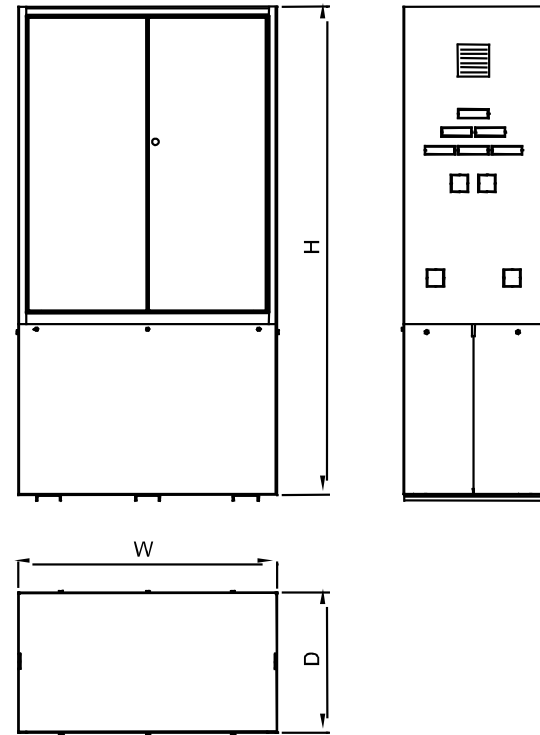
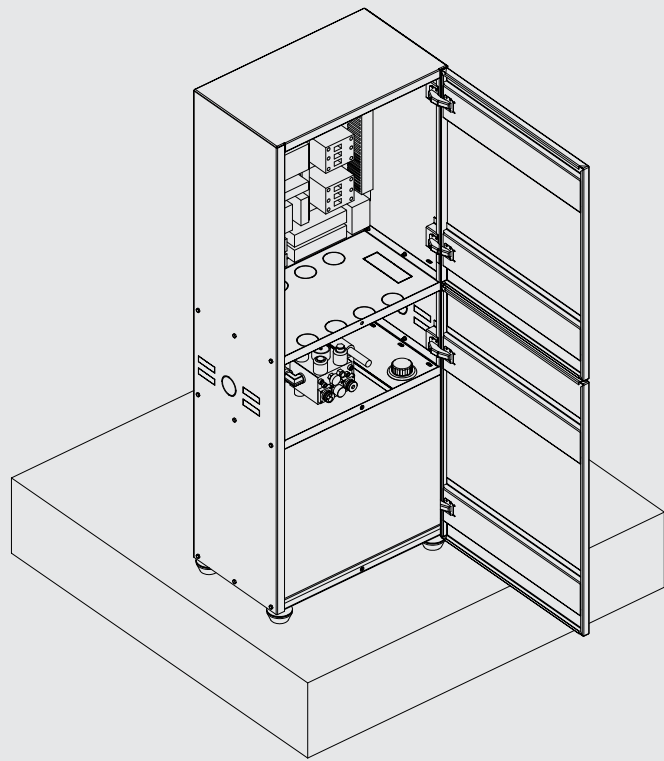

	W (mm)	H (mm)	D (mm)
T215 BL*	980	1760	480
T325 BL*	980	2060	480
T120*	850	1600	460
T150*	1030	1700	
T250*	1230	1800	600
T350*	1230	2000	600
T450*	1480	2000	600
Compact T50	720	1240	400
Maison T80	700	1600	370
Maison T150	950	1600	570
BL T150 Blain	1020	1740	560
BL T150 Bucher	1020	1900	560
BL T250 Blain Nar	1200	2050	350
BL T250 Bucher Nar	1200	2300	350
BL T350 Blain	1270	2070	560
BL T350 Bucher	1270	2220	560
BL T450 Blain	1480	2070	560
BL T450 Bucher	1480	2220	560

\* extra protection against oil leakage



# DOORS



# DOORS

## Automatic doors

- Modernization landing door
- Side / Central opening
- Frameless
- Helping assembly tool (upon request)
- No fire resistance

### SIDE OPENING

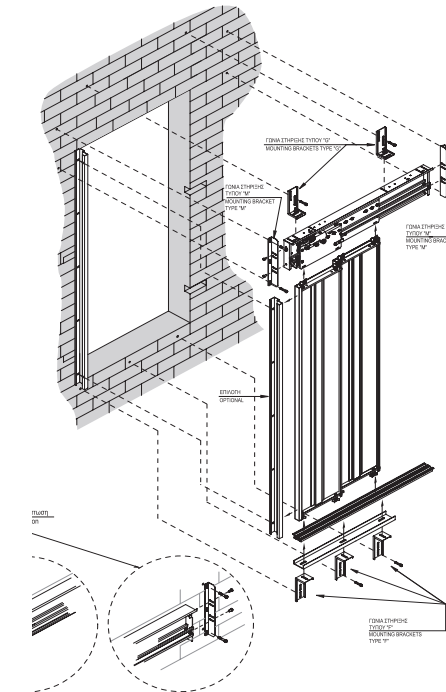

### CENTRAL OPENING

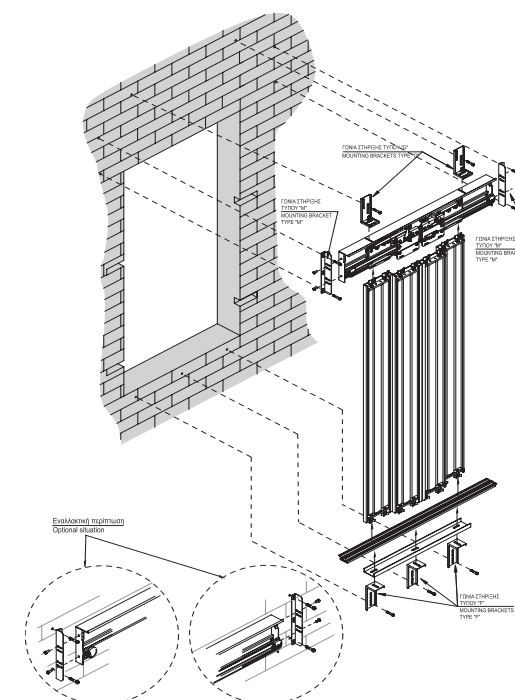

### ASSEMBLING TOOL

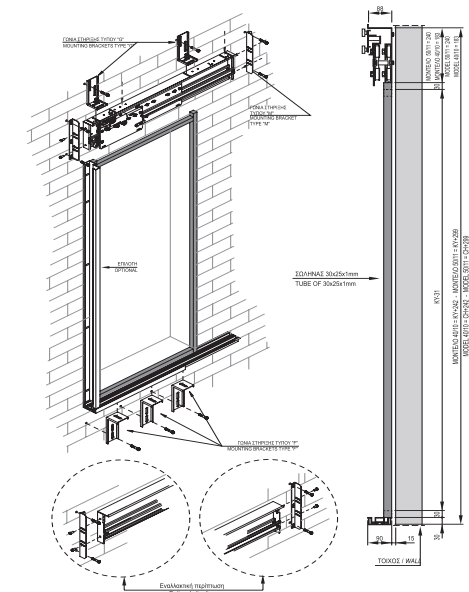

### ASSEMBLING TOOL

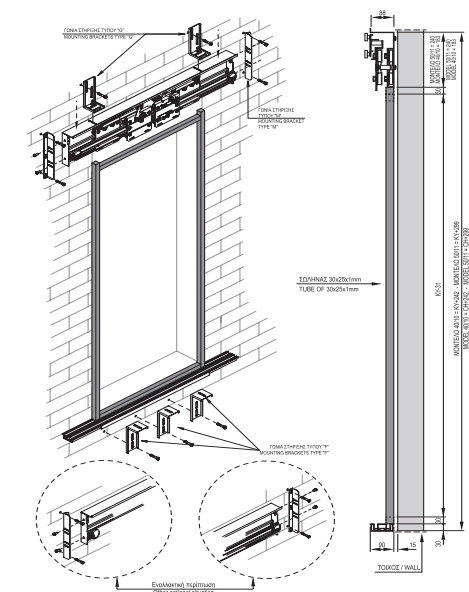

Central Big Vision



Central Full Glass

Door Type	Model	Top view	Certificate (Depenting on the dimension and the model)	Clear opening (mm)	Clear Height (mm)
C2H	40/10		E 120 /EI60 / EI120 / EW 60	600-1400	2000-2400
C2H	50/11			600-2000	2000-3000
C4H	40/10		E 120 /EI60 / EI120 / EW 60	600-1400	2000-2400
C4H	50/11			600-3000	2000-3000
C4H	Slim		E 120	600-1100	2000-2100
C6H	50/11		E 120 /EI60 / EI120 / EW 60	1200-3000	2000-3000
C8H	50/11			1400-3000	2000-3000
T1H	40/10		E 120 /EI60 / EI120 / EW 60	600-1000	2000-2400
T1H	50/11			600-1200	2000-3000
T2H	40/10		E 120 /EI60 / EI120 / EW 60	600-1200	2000-2400
T2H	50/11			600-1600	2000-3000
T2H	Slim			600-1100	2000-2100
T2H	Premium			E 120 /EI 60	700-1400
T3H	40/10		E 120 /EI60 / EI120 / EW 60	600-1200	2000-2400
T3H	50/11			600-2000	2000-3000
T3H	Slim			E 120	600-1100
T4H	50/11		E 120 /EI60 / EI120 / EW 60	600-2000	2000-3000

Big Vision and Full Glass panels are available for certain dimensions and models.

# DOORS

## Automatic doors

### COMBINATION SEMI-AUTOMATIC / AUTOMATIC (SILL 70MM)

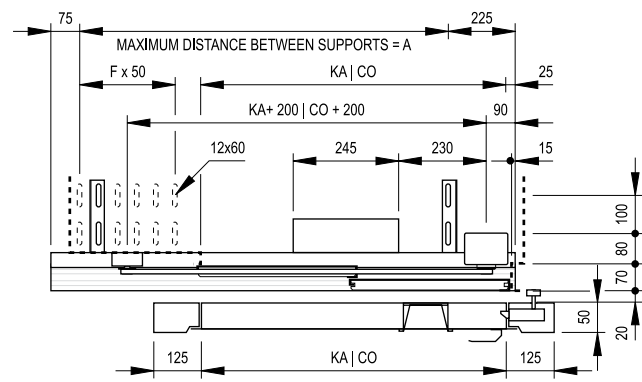

EN81-20 distance between doors 30mm

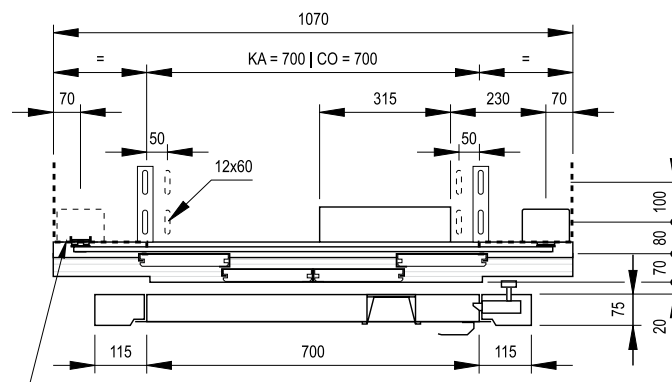
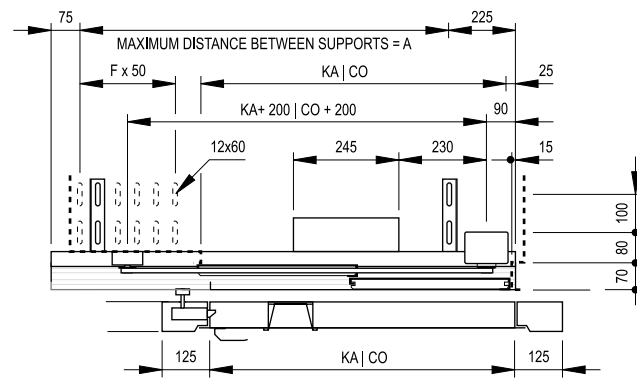

IT IS POSSIBLE TO INSTALL THE MOTOR ON THE OPPOSITE SIDE

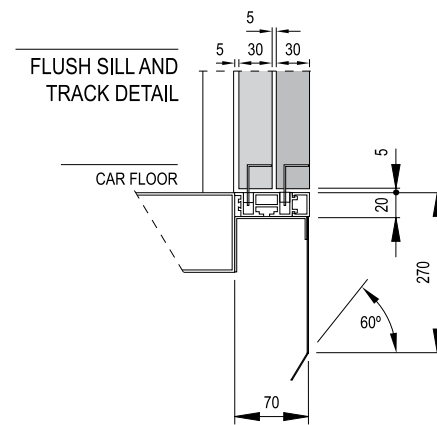

### SLIM DOORS

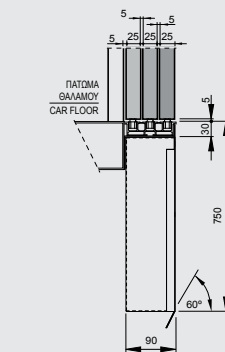
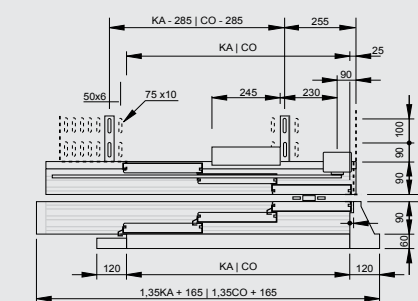
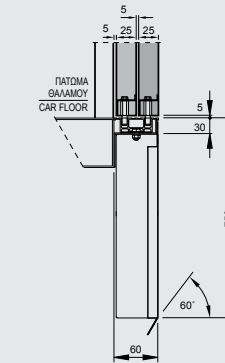
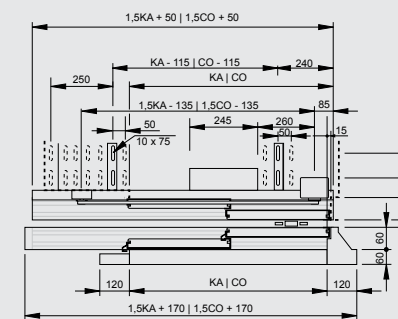
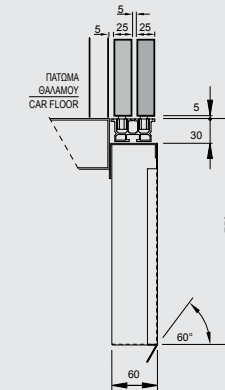
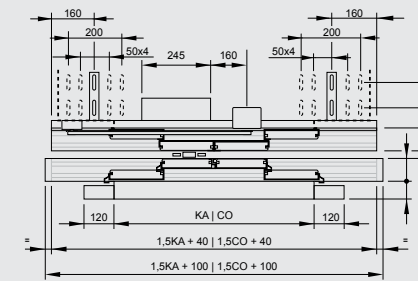
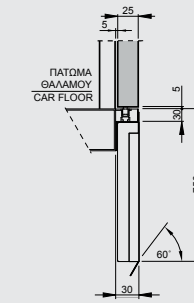
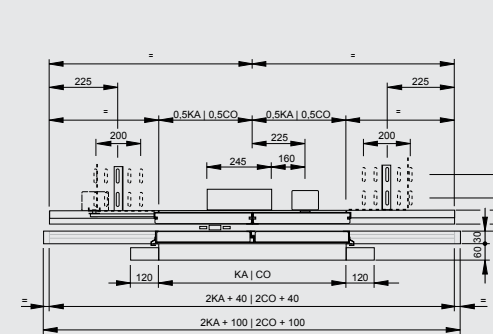



## DOORS

# Semi-automatic / Hinged doors



C310



C520

Model	Clear opening	Clear height	CO E120	CH E120
Klefer-Classic	500-1350	2000-2950*	500-1000	1700-2300
Skotia-C310-Luxury	600-1350	2000-2950*	600-1000	1700-2300
New skotia- M310-Elegance	600-1000	2000-2350*		
Big Vision with frame C520 - Luxury glass with frame	600-1350	2000-2900*		
E-29 C710	600-1000	2000		
Small Vision (andreas zapatinas   design) M510	600-1000	2000		
Big Vision (andreas zapatinas   design) M710	600-850	2000		
Surf (andreas zapatinas   design) F710	600-900	2000		
Thunder (andreas zapatinas   design) - F310	750-1000	2000		
Space (andreas zapatinas   design) F510	700-900	2000		
Special choices				
Two panel classic model	800-2500	2000-*		

\* clear height depending on the finishing and clear opening  
Available materials: Powder paint (Epoxy) in various colors, Skinplate, Stainless Steel, Wood veneer. Some restrictions on dimensions apply



## DOORS

# Cabin Door Modernization solution

## SPECIAL DOOR SOLUTIONS

# Semi-automatic / automatic doors

New, fully equipped, compact, versatile and quiet.

### TAPAJUNTAS

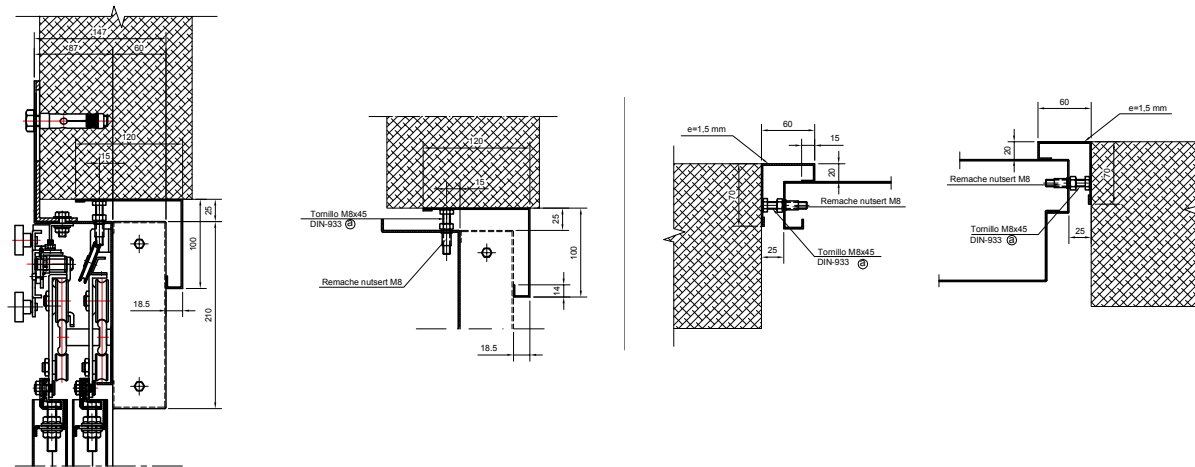

### NEW CABIN DOOR PAIRED TO OLD LANDING DOOR

**!** Available for all models of landing doors

Before



After



### DITEC SOLUTION

By placing the special mechanism, we can achieve automatic opening and closing of the semiautomatic lift doors, either by simple mode operation with button or remote control (not included), or in full cooperation with the elevators electronic panel, each is a similar function to that of automatic doors.



Technical Specifications / Main system & control panel

Description	Detail	Description	Detail
Model	SPRINT	Remote control	•
Control Panel	165	Braking / Slowing down	•
Main power supply	230V~/50-60Hz	Includes ON / OFF switch, located in accessible spot	•
Motor	for 1 Motor 24VDC	ODS - Obstruction detection system	•
Energy Saving	Energy saving when in use	Automatic power supply system in case of power failure (emergency supply evacuation)	•
Motor power supply	24V = / 5 A	Open control	•
Power supply accessories	24V= / 0,15A	Force adjustment control	•
For semiautomatic doors	from 600mm to 1000mm	Close door	•
Encoder	•	Speed adjustment	•
Automatic timed close control	•	Stop safety device	•
Push opening - PUSH & GO	•	Emergency reverse	•



Enhance passenger protection with the addition of certified door safety edges from a wide range of types and reliable brands.

# DOORS

## Folding / BUS type doors



Folding door (BUS type - G5 EN 8120/50)

Model	Clear opening	Clear height
G5 - Sill 100mm	550-1000	2000-2100
Additional panel types		
Sheet metal	550-1000	2000-2100

Folding doors are not available in wood finishing



FD710  
Inox  
andreas zapatinas | design



FD320  
Inox

Folding door (BUS type)

Model	Clear opening	Clear height
G3-Sill 100mm	550-1000	1700-2200
G3 Modernization-Sill 80mm	550-1000	1700-2200
G3 Modernization-Sill 80mm-header 63mm	550-1000	1700-2200
G3 Titan-Sill 100mm	1050-1400	2000
G3 with inverted operator-Sill 100mm	550-1000	1700-2200
G3 with inverted operator-Sill 100mm-header 63mm	550-1000	1700-2200
G3 with inverted operator-Sill 80mm	550-1000	1700-2200
G3 with under driven operator-Sill 100mm	550-1000	1700-2200
G3 with under driven operator-Sill 80mm	550-1000	1700-2200
Additional panel types		
Small Vision panels	650-1000	1700-2200
Big Vision panels	650-1000	1700-2200v
Asymmetric panels	600-1000	1700-2200
Asymmetric Big Vision panels	700-950	Depends on the model
Aluminium Big Vision panels	550-1000	2000
FD710 "Hourglass" panel	600-1400	1800-2200
FD510 "Bullets" panel	600-1400	1800-2200
FD310 "2coloured" panel	550-1400	1700-2200
FD720 "Tribal" panel	650-1400	1800-2200
FD530 "Ellipsis" panel	600-1400	2000

Folding doors are not available in wood finishing

### MODERNIZATION (SILL 80MM)

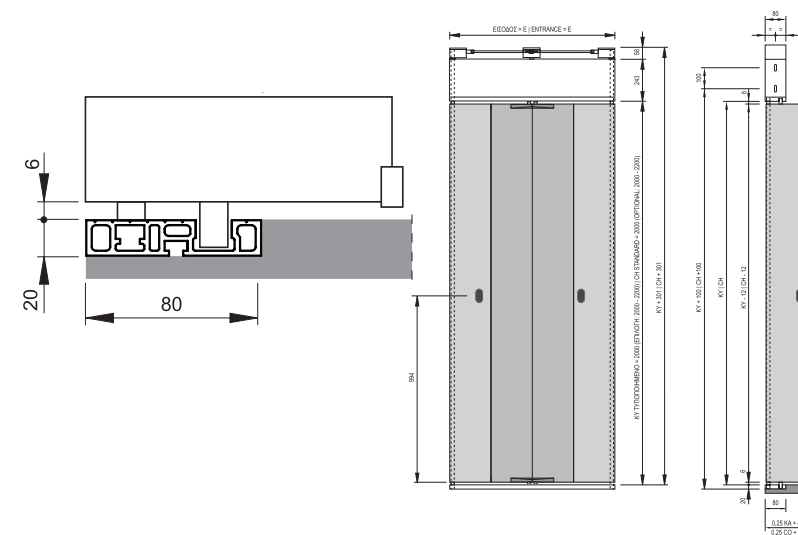

### MECHANISM UNDER LOW HEADROOM

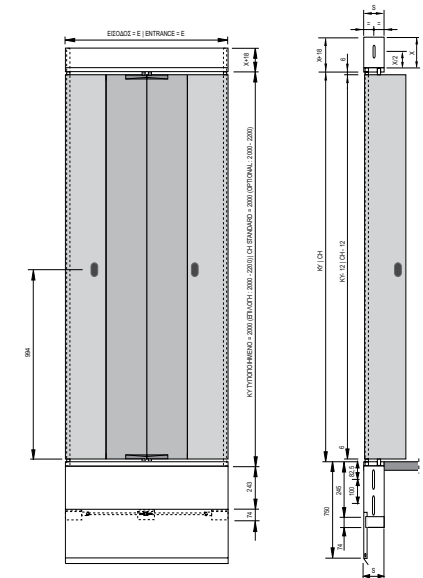

### INVERTED MECHANISM

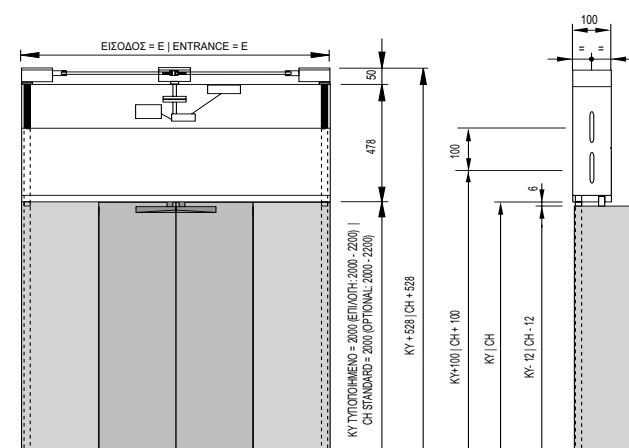

### ASYMMETRIC

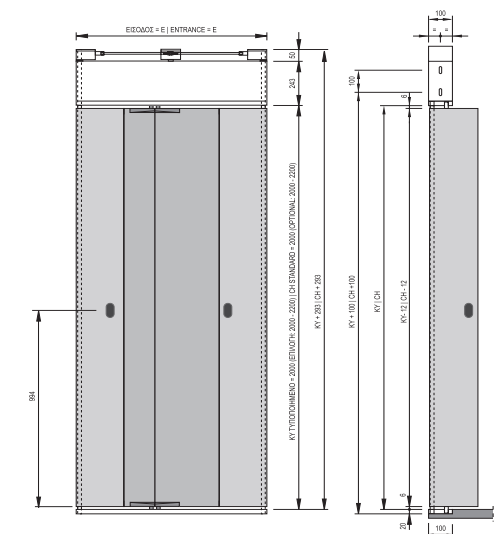



# INTERIOR MATERIALS





# INTERIOR MATERIALS

## Ceilings

Options for ceilings are available with Purity cabins.  
For other cabin types, please contact your sales representative.  
All options are in compliance with EN81.20.



C10

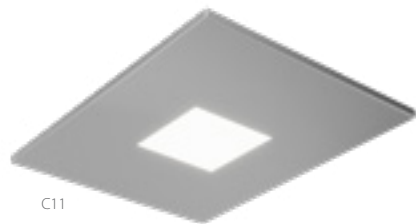

C11



C12

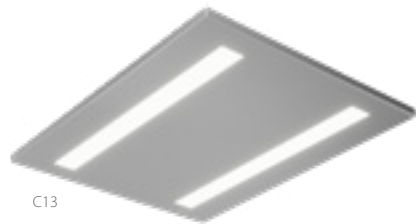

C13

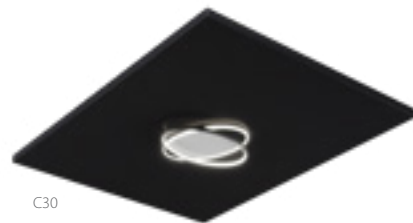

C30



C40



C41

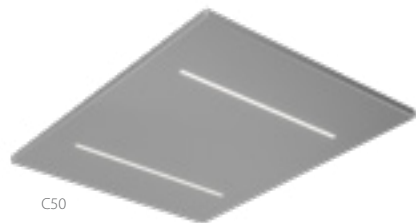

C50

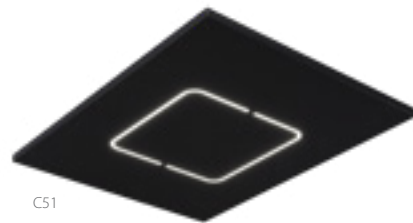

C51

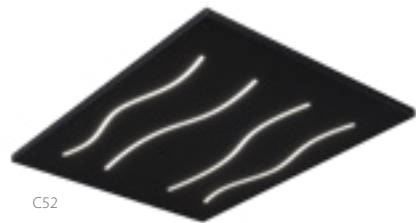

C52

# INTERIOR MATERIALS

## Handrails

Options for handrails are available for all cabins exc.  
All options are in compliance with EN81.20.



K2

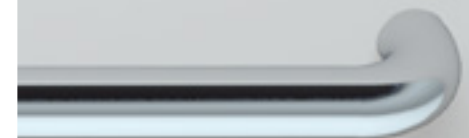

K3 According to EN81.70

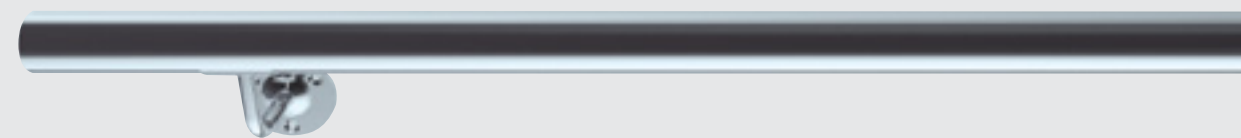

K6



# INTERIOR MATERIALS

## Floors

Options for floors are available for all cabins.  
All options are in compliance with EN81.20.

### RUBBERS



6801

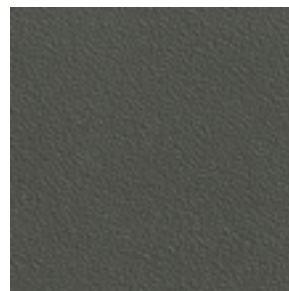

6727



6768

### ARTIFICIAL GRANITES

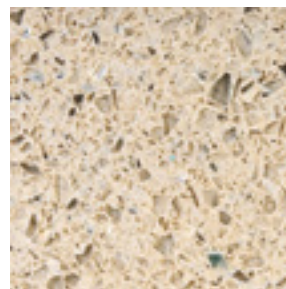

Regal Beige

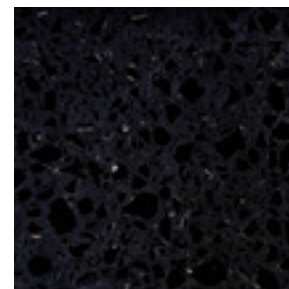

Regal Black

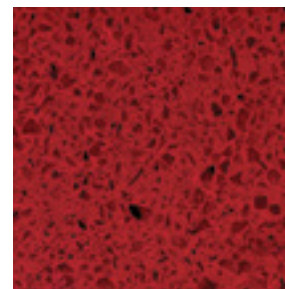

Regal Red



Regal White

Floor recess is also available

Colours may differ slightly from those shown in the manual  
owing to the limitations of the printing process

### VINYL

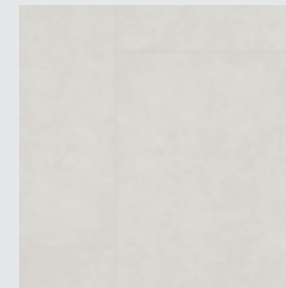

Light Cement

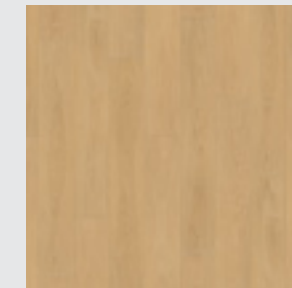

Timber Tone

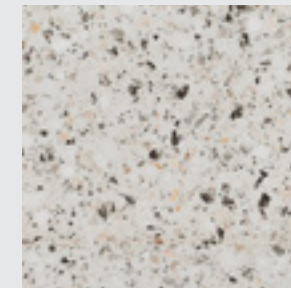

Mosaicon

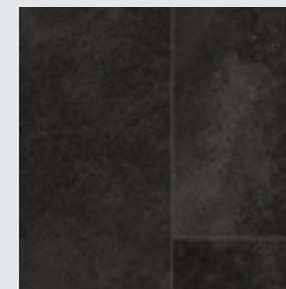

Oxytone Concrete

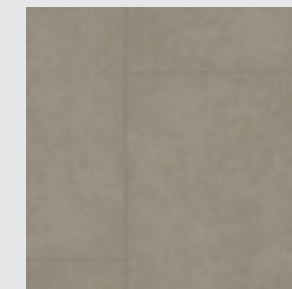

Concrete Vibe

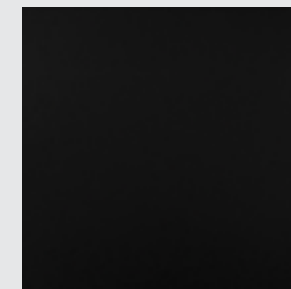

Black Luxe



# OPERATING PANELS

## Car Operating Panels

### FLUSH MOUNTED

AKC BES BLUE LINE XX\*    AKC BES XX\*    AKC BES L XX\*



Stainless Steel Mirror

AKC HB XX\*



Flush Mounted COP's	(W) Width x (H) Height			
	Type	Number of Push buttons recesses	Faceplate Dimensions (W x H)	Embedded Box Aperture Dimensions
AKC HB:		4 to 8	200 x 710	660 x 170
COP's with embedded dox,		10 to 16	200 x 880	825 x 170
without telephone box		18 to 22	200 x 1050	995 x 170
COP's with embedded dox		10 to 16	200 x 1050	995 x 170
And telephone box				

Available with any type of push button or floor position indicator (display)  
\*XX: the number of push buttons recesses

### SURFACE MOUNTED

AKC-SM-BA  
BLUE LINE XX\*



(W)225mm x (D)35mm x (H)1100mm

HALO SC600

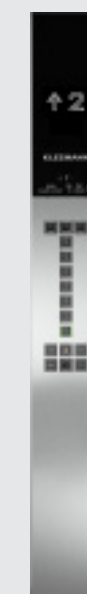

(W) 225 mm x (D) 14 mm x (H) 1900 mm

HALO SC500



(W) 225 mm x (D) 14 mm x (H) 1000 mm

DKC  
(DOT) Display



(W) 200 mm x (D) 24 mm (H) 1000 mm

DKC  
(TFT Display)



### HORIZONTAL

FPY-1000 BLUE LINE



(W)1050mm x (D)65mm x (H)150mm

**Satin or mirror Stainless Steel faceplates**  
Special Stainless Steel faceplates available upon request

Colors may differ slightly from those shown in the brochure, owing to the limitations of the printing process.

Pictures of the materials illustrate detailed part of each material and not its rendering on the cabin surface.



# OPERATING PANELS

## Landing Operating Panels & Landing Indicators

### FLUSH MOUNTED

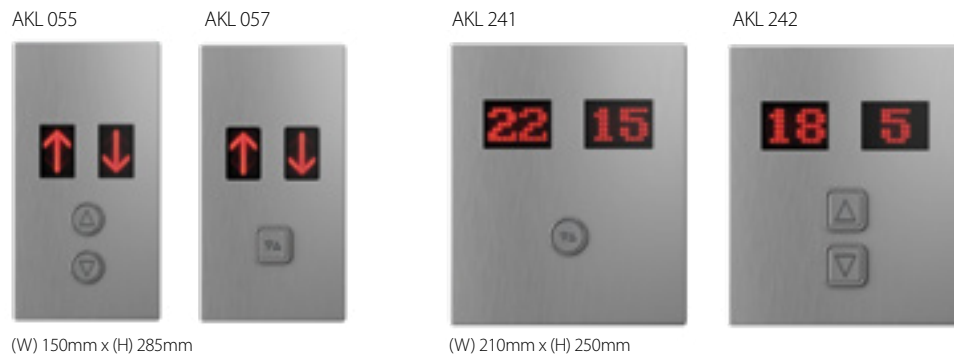
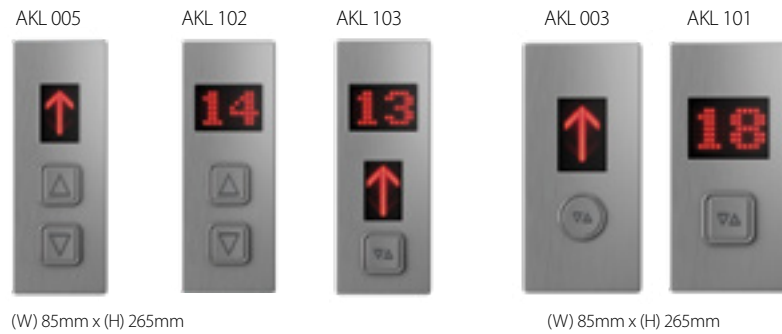

Please contact your sales engineer for material's compatibility restrictions.



### SURFACE MOUNTED



Dimensions : (W) 108 mm x (D) 10 mm x (H) 230 mm

### LANDING OPERATING PANELS



HALO SL621 Dimensions with display  
(W) 95 mm x (D) 14 mm x (H) 335 mm

HALO SL630 Dimensions without display  
(W) 95 mm x (D) 14 mm x (H) 225 mm

### FLUSH MOUNTED INDICATOR

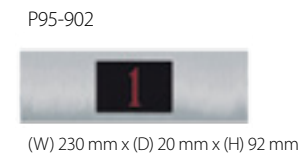

### SURFACE MOUNTED INDICATOR



### PUSH BUTTONS





# EXTRA FEATURES OF OPERATING PANELS

## CARD READER

Usefull accessory for COP and LOPs to grant the final users access control for car and landing calls , Blue tag cards can be programmed in order to activate dedicated group of car and landing calls. The user presents the blue tag to the sensor, the temporary available call buttons are flashing. He press the call button.



## TRANSPONDER ES\_MEGA COMPLETE

Card reader (Electronic keyswitch for mt-42 design)

Weight: 0,049  
Dimensions: 6,9x4,4x2,6



## BLUE TAG CARD

Card reader card for ES\_mega

Weight: 0,006  
Dimensions: 6x3,3x0,8

## KEYSWITCH MT42

A keyswitch is usefull in order to activate specific functions. As you can see there are 3 variations.  
One extract position. Can be used to activate a function so long the key is placed and turned in on position. Most frequently it is used as an attendant key switch.  
Spring return. Can replace any kind of buttons. Most frequently call buttons.  
Two extraction position. It's used in cases we like to allow or deny the operation of another device for a long time period. Most frequently it is used to control a call or o group of calls.  
Car call / landing call release functiopr.

Weight: 0,145  
Dimensions: 6,3X4,5X4,5



## SECRET CODE

A secret call is used to replace 1 up to 4 keyswitches. Up to 4 different codes can be used in order to replace a combination of 4 different keyswitches ( spring return or 2 position keyswitches )



## TRANSCIEVER

Remote control, it is used to give car or landing calls from distance. Very usefull for VIP users, or in case of a car lift or an industrial goods lift where the lift user cannot easily reach the push buttons while inside the vehicle. Another special use is to operate it in order to bypass momentary another access control device ( a spring return contact used to give a call )





# INSTALLATION PERSONAL PROTECTION



## INSTALLATION

# Guide rails

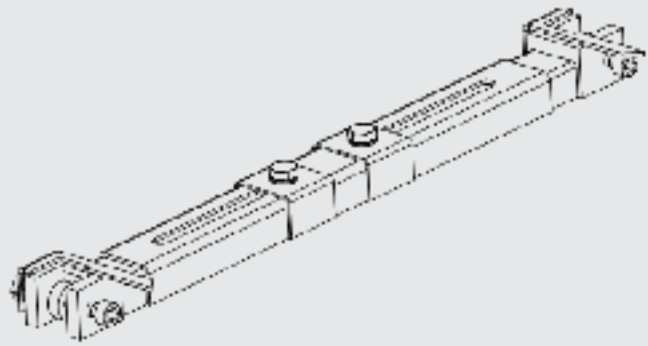

### ALIGNMENT DEVICE

Ensures DBG during installation

1. Right extension
2. Base
3. Left extension
4. Alignment brackets
5. Reinforcement

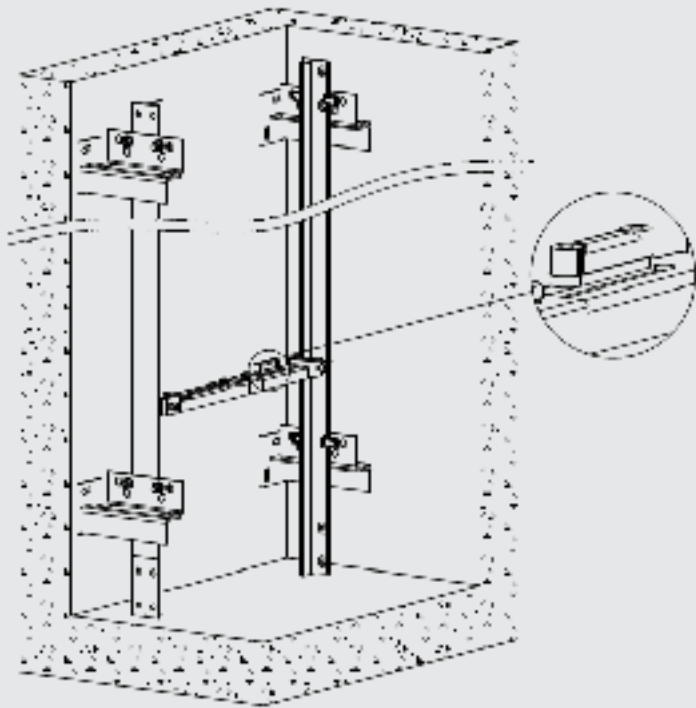

### PLUMB LINES BASE

The plumb lines base is a tool which helps us to drop the plumb lines into the shaft, so we can place the guide rails and the doors accurately.

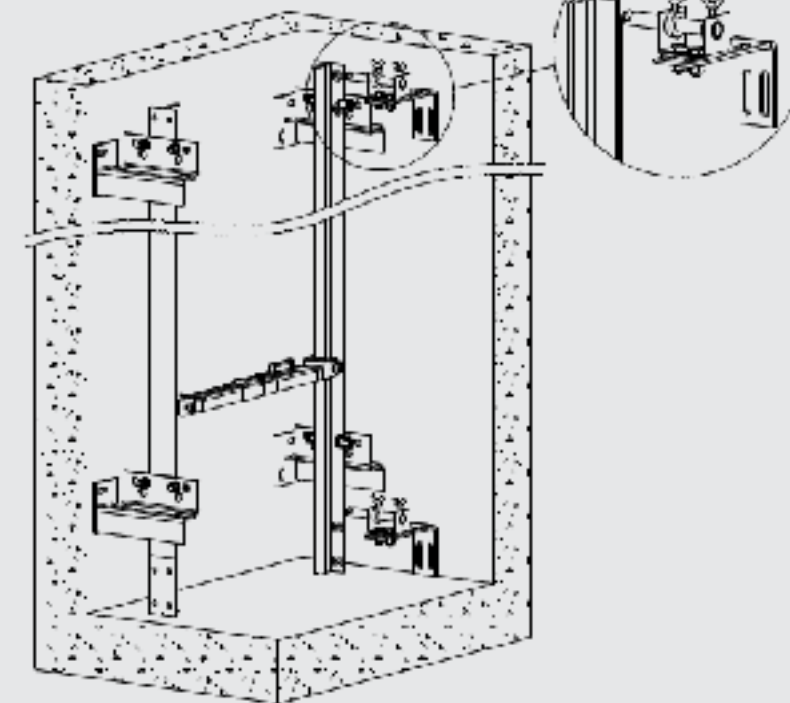
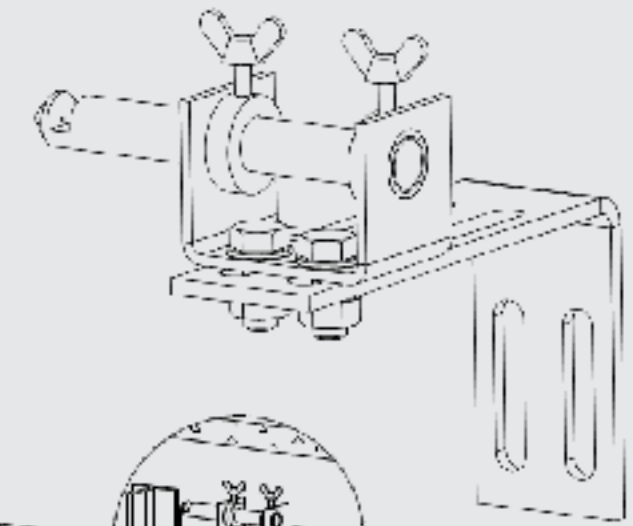



## INSTALLATION

# Tools for Scaffoldless Installation

This is a part of the ATLAS EU 2:1 MRL.  
Through this mechanism the installation takes place without the use of scaffold in the shaft.  
Complied to 2006/42/EC and EN 81.20. Max working load 1410 kgr.

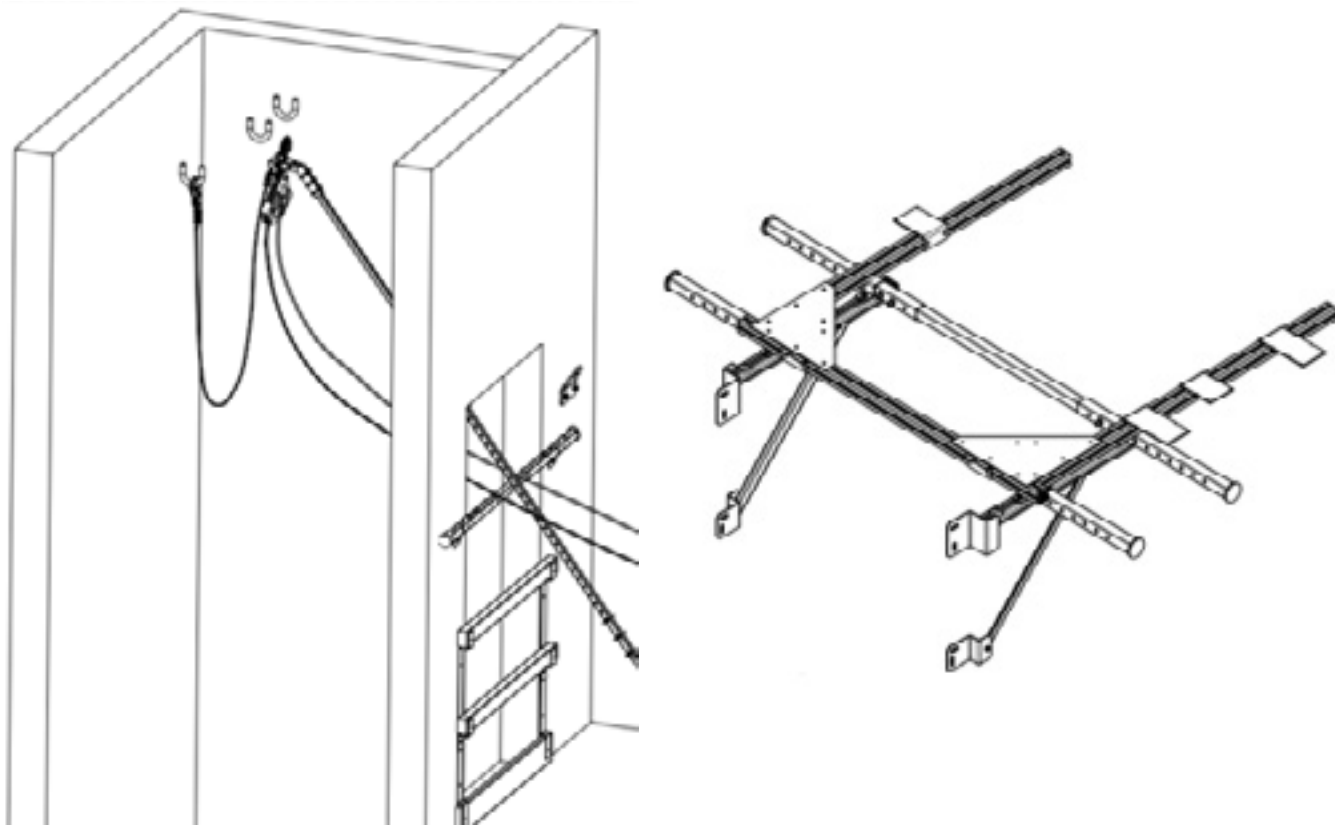

KLEEMANN Scaffoldless is a solution for quick, easy, and flexible installation. Committed to progressive technical knowledge and innovative research schemes, the KLEEMANN R&D team, designed and developed a method that now makes the installation process both safer and faster. KLEEMANN provides special tools to erect the elevator with the minimum assistance from the builder.

## ADVANTAGES

- Easy and safe installation
- Cost saving installation
- Time saving installation

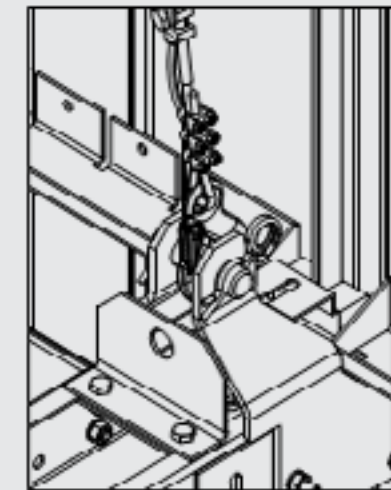
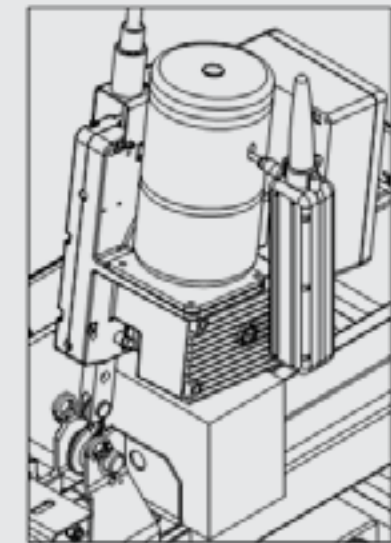
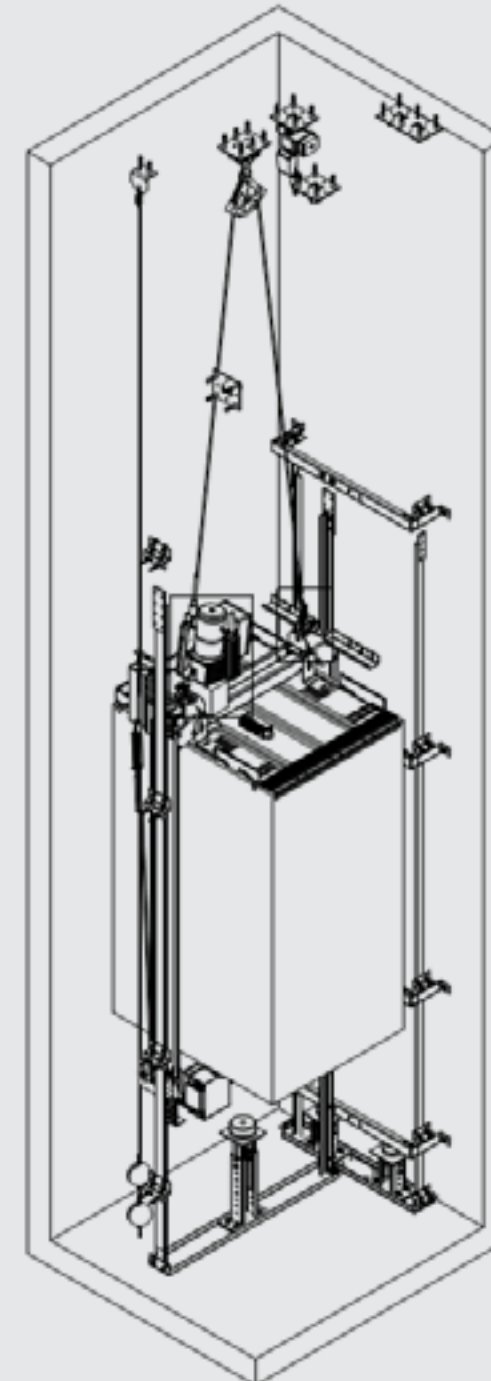



# INSTALLATION

## Tools



### DOUBLE WRENCH SW42 – SW46

Adjustment of car frame inclination (ZU210 / ZU270 / UCF)

### COMBINATION WRENCH SW36 – SW46

Adjustment of car frame inclination  
(ZU170 / ZU180 / LSF / LEF 1000/1200)  
Tightening ram bolt M30 (Φ70 - Φ130)

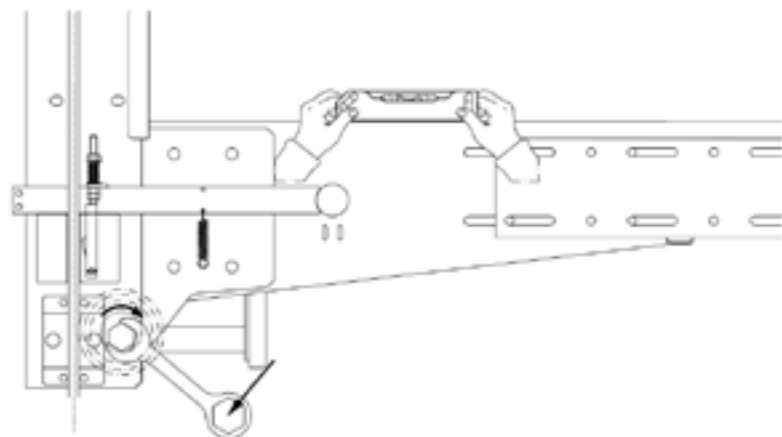
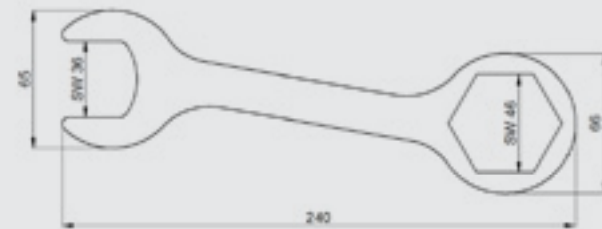

### RING WRENCH SW55

Tightening ram bolt M36  
(Φ150 - Φ210)

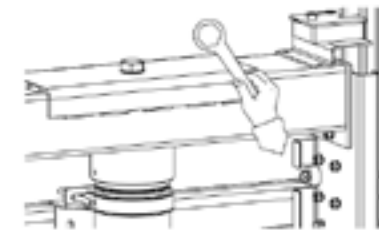

### RAM CLAMP

Tighten split piston.

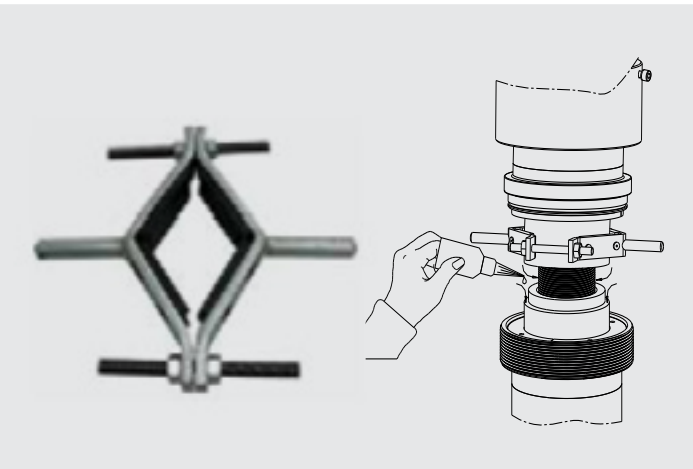

### RAM HEAD EXTRACTOR

Extracts the ram head  
(usually when we replacing seals)

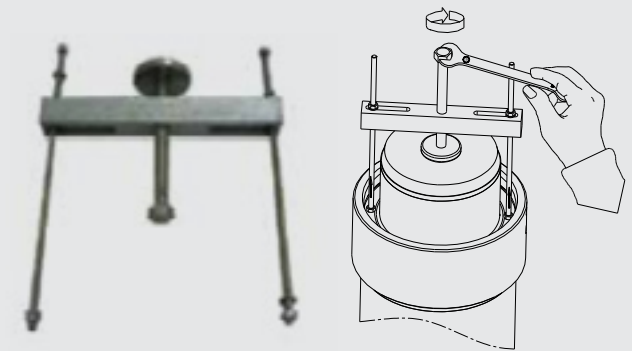

### RAM HEAD INSERTER

Inserts the ram head  
(usually when we replacing seals)

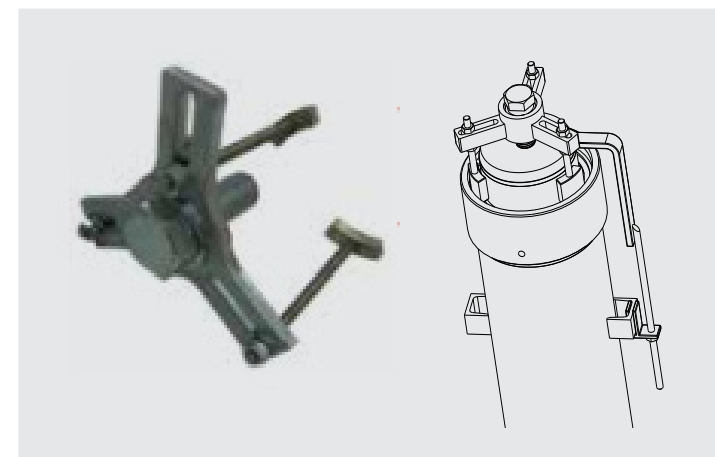



# PROTECTION

## Personal Protective Equipment (PPE)

One of our values in KLEEMANN is Safety  
Clothing or equipment designed to protect workers.



Shop all  
and save time



Safety  
above all



### GLOVES FOR GENERAL USE NITRIFIT NR 10

Material : Polyamide, extra Nitrile reinforcement in palm area. Black. Excellent comfort and fingertip feeling for manual labour.  
Conform to EN388



### GLOVES FOR GENERAL USE PERFECT POLY BLACK

Material : Polyamide, extra polyurethan reinforcement in palm area. Black. Excellent comfort and fingertip feeling for manual labour (ie use of mechanical tools) Slip Resistant  
Conform to EN388



### GLOVES FOR GENERAL USE PU WHITE

Material : Polyamide, extra polyurethan reinforcement in palm area. White. Excellent comfort and fingertip feeling for manual labour (ie assebly)  
Slip Resistant  
Conform to EN388



### CUT PROTECTION GLOVES EURO CUT 3 P300

Material : high-tensile strength fibers (HPPE, grade 13) polyurethan reinforcement in palm area  
Elastic cuff for extra protection  
Use in Dry / slightly oily surfaces  
Free of silicone  
Conform to EN388 (level 3)



### WELDING GLOVES

Material : naturalleather.  
Extra internal coating  
Cuff 150mm long Specs : labels 414X4X  
100°C 31,4s, 250°C 10,7s  
Conform to EN388, EN420, EN407



### MASK CHIMILUX

Elastic adjustment straps, PVC frame  
4 ventilation holes that blocks dust and particulates  
Poly carbonate glare free lens  
Marking : 2.1.2 1 BN,  
Conform to EN170



### PROTECTION GLASSES OPEN TYPE VISILUX

Easily fit with vision glasses (visitor glasses)  
circumferential protection

Weight : 45 gr  
Specs : Polycarbonate frame FT/ transparent lens :  
2-1.2 1FTK, thickness 2,2 mm  
Conform to : EN166, EN170



### PROTECTION GLASSES OPEN TYPE ECOLUX

Plastic frame with soft touch  
Adjustable arm length  
circumferential protection  
Poly carbonate transparent lens thickness 2,2 mm  
Conform to EN166- EN172



### GAS WELDING GLASSES

PVC frame, Ventilation holes  
Lifted Lens Ø50mm , IR5  
Elastic adjustment straps  
Conform to EN170, EN169, EN166



### WORKING WAIST PROTECTION BELT

Ergonomic design  
Elastic supports suspendres  
Velcro Straps fastening



# PROTECTION



## SAFETY SHOES

High quality leather, metal protection in toe area, removable sole.  
Antistatic, internal breathing coating  
Slip resistance SRC,  
Polyurethane, energy absorption sole  
Resistance in oil and Hydrauliccarbon.  
Internal reinforcement in front and back side  
Conform to EN ISO 20345:2011 S1P - SRC



## SAFETY SHOES S3 TIBER NAVY/BLUE

Water resistant  
Slip resistance sole due to SRA standard  
Antistatic  
Toe protection with synthetic coating (200 Joule)  
Resistance in oil  
Conform to BS EN ISO 20345:2004/A1 2007



## HEAD FLASHLIGHT

Elastic adjustment straps  
3 levels luminescence  
90° rotation



## WELDING MASK (VELDO) WURTH

Adjustment DIN: 9-13  
Sensor speed: 1/25.000 s  
View area : 98 x 43 mm  
Power supply : solar cell  
Twin optical sensor  
High quality glass  
Weight: 460 g  
Conform to CE, ANSI, CSA, AS/NZS



## DUST MASK FFP1

Breath out valve  
Electrostatic propylene filter  
External coating polypropylene SMS /  
Internal coating polyester  
Elastic adjustment straps  
Protection against dust, humidity

Aluminium nose adjustment / bracket  
Use , max 8 hours  
Weight : 8 g  
Conform to EN 149:2001 + A1:2009

## CHEMICAL MASK FFP2 SL-VO

Breathou valve  
Activated carbon filter  
External coating polypropylene SMS /  
Internal coating polyester  
Conform to EN 149: 2001 (+welding)



## FALL ARREST SYSTEM

provide an operative with the maximum amount of freedom and movement when working at height  
One size, fully adjustable  
Anchoring back and double front points  
Safe line : Optional  
Conform to EN361, EN358



## EARPLUGS

Made by soft foam polypropylene  
Easily fitted in the ear  
Without additional cord  
Package 1000pcs  
SNR: 36db  
Conform to EN3522



## HEARING PROTECTION EARLINE MAX 200

PVC pillows  
Weight : 166 gr  
SNR : 27 dB H:33 M:24 L:15  
Conform to EN 352-1



## WORK VEST

Photoluminescent Vest with horizontal reflecting stripes.  
Material : 100% polyester  
Weight : 130gr/m2  
Conform to EN471 class 2,2



## KNEE PADS

EVA knee pads with foam reinforcement  
Velcro Straps fastening

## SAFETY HELMET OPAL

UV protection  
Internal coating against sweat 20 cm thickness  
adjustable in 6 set points



Weight 340 gr  
Colours : white, yellow, orange, blue, green, red  
Conform to EN 397 (UV protection)



## MOD KITS



# MOD KITS

## A3 UCM

Unintended car movement can be prevented with the installation of KLEEMANN A3 kits. Kits enable the lift to detect car movement with unlocked landing door and open car door. In this case safety systems block the car immediately and keep it stopped until the problem is solved.

### KIT A3.1

New bidirectional safety gears. This system can be easily fitted in the existing car sling.



Overspeed governor anticreep

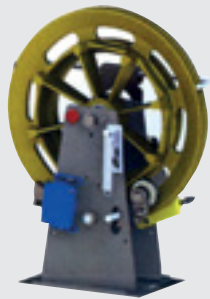

New controller



### KIT A3.2

New machine gearless or geared with slow shaft brake.



Overspeed governor



New controller



### KIT A3.3

New bidirectional safety gears. This system can be easily fitted in the existing car sling.



Overspeed governor



Electronic interface that detects UCM. No further modification in the existing controller is required.

# MOD KITS

## EN 81-21

EN81-21 kit upgrades safety in existing lifts.

### KIT EN81-21 TR

#### LOW PIT

Extra locking device  
Apron



Base and maintenance beam low pit

#### LOW HEADROOM

Extra locking device  
Split balustrate base  
and maintenance beam  
low headroom

Controller



### KIT EN81-21 HYDRAULIC

#### LOW PIT

Extra locking device  
Apron



Pit prop

#### LOW HEADROOM

Extra locking device  
Split balustrate

New Controller

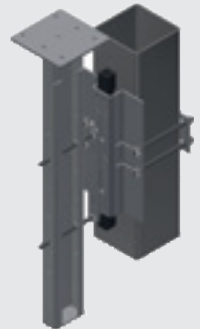

## MOD KITS

# Convert acting 1:1 to 2:1

Gearless machines are designed for 2:1 acting and old elevators are mainly 1:1. The use of gearless machines in existing lifts has economical and technical limitations. The conversion kit can be easily fitted without extra holes in the shaft. Thus you can accomplish both improved ride quality and energy saving in affordable cost.

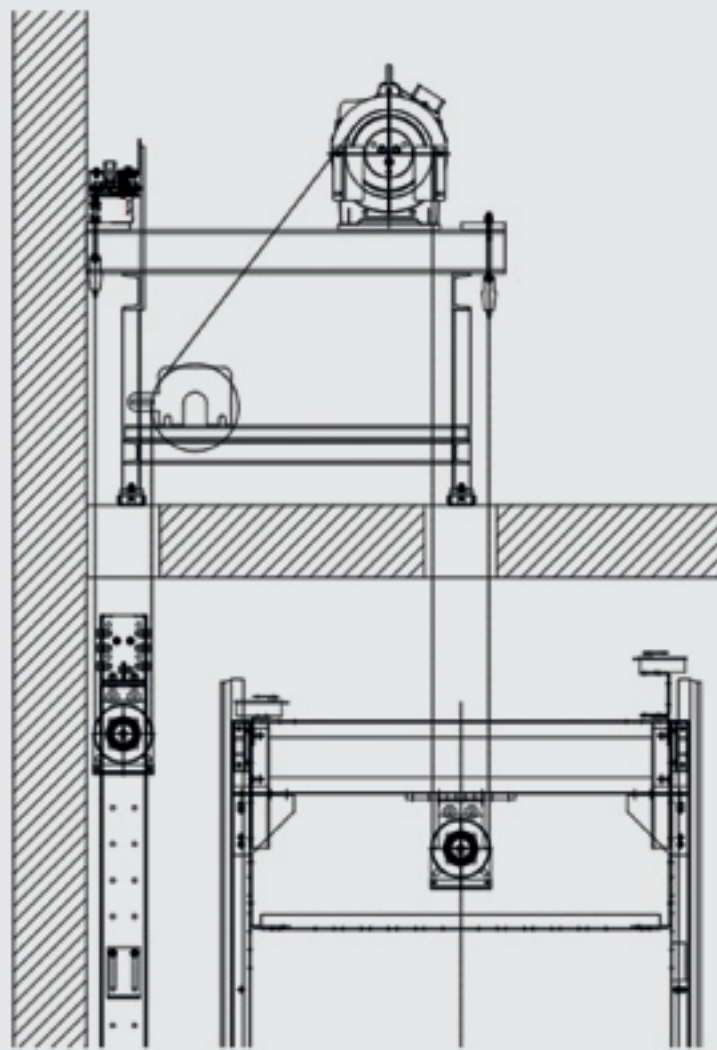

New parts  
Gearless machine with base  
Kit of pulleys  $\Phi 160$   
Rope  $\Phi 6,5$  Drako 250T  
Controller  
Overspeed governor

## MOD KITS

# Cabin Maximisation

Optimum use of available shaft eliminates required space for mechanical parts and maximise internal cabin area.

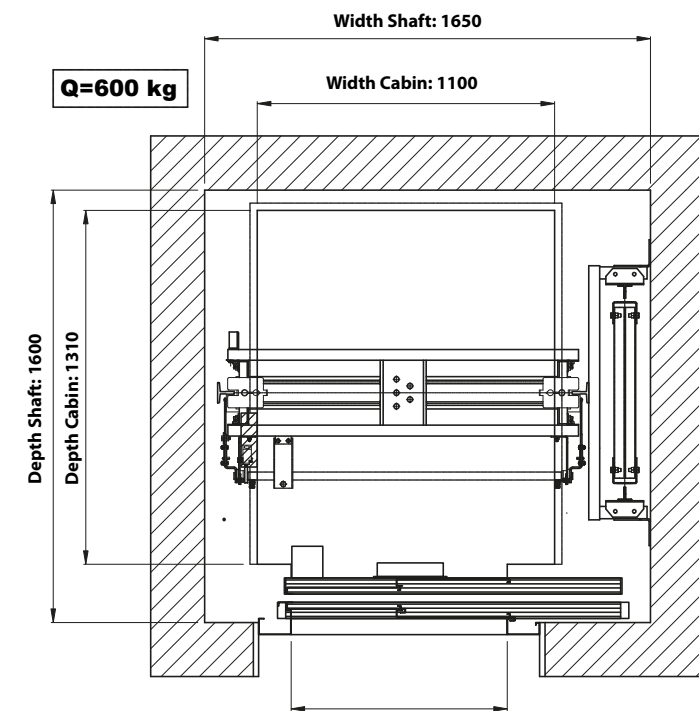
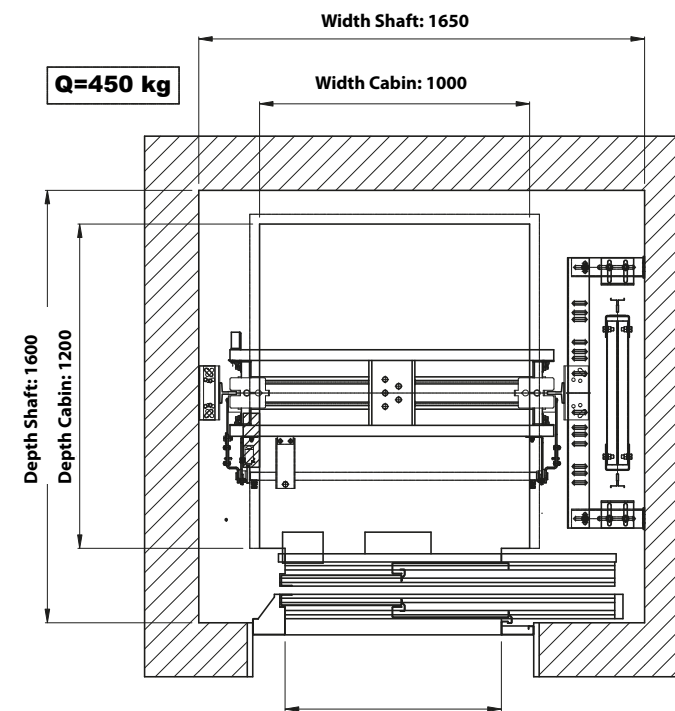



## MOD KITS

# Reduced Headroom Mechanical Safety device (Hydraulic)

- Mechanical travel limitation is used in case of reduced headroom and pit.
- A beam placed under the sling in order to create protected area in the pit
  - A beam placed in the headroom in order to create a protected area on top of the cabin

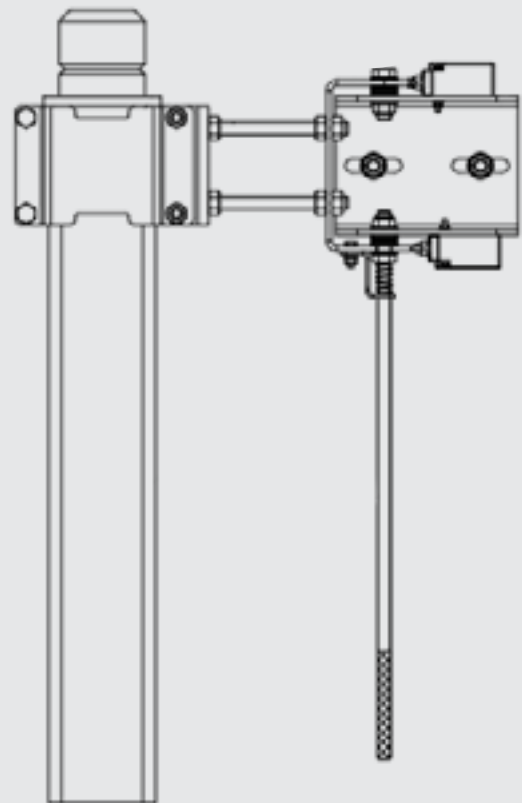

### NORMAL MODE

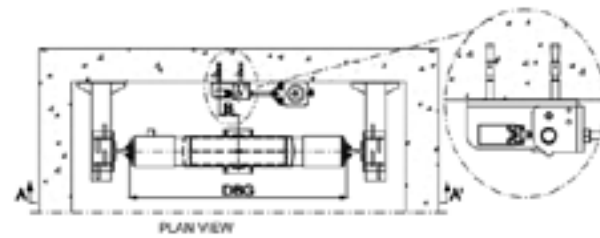

### INSPECTION MODE

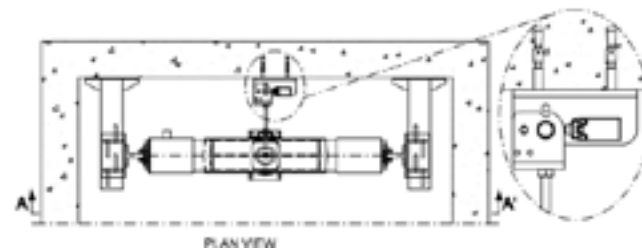

### INSPECTION MODE

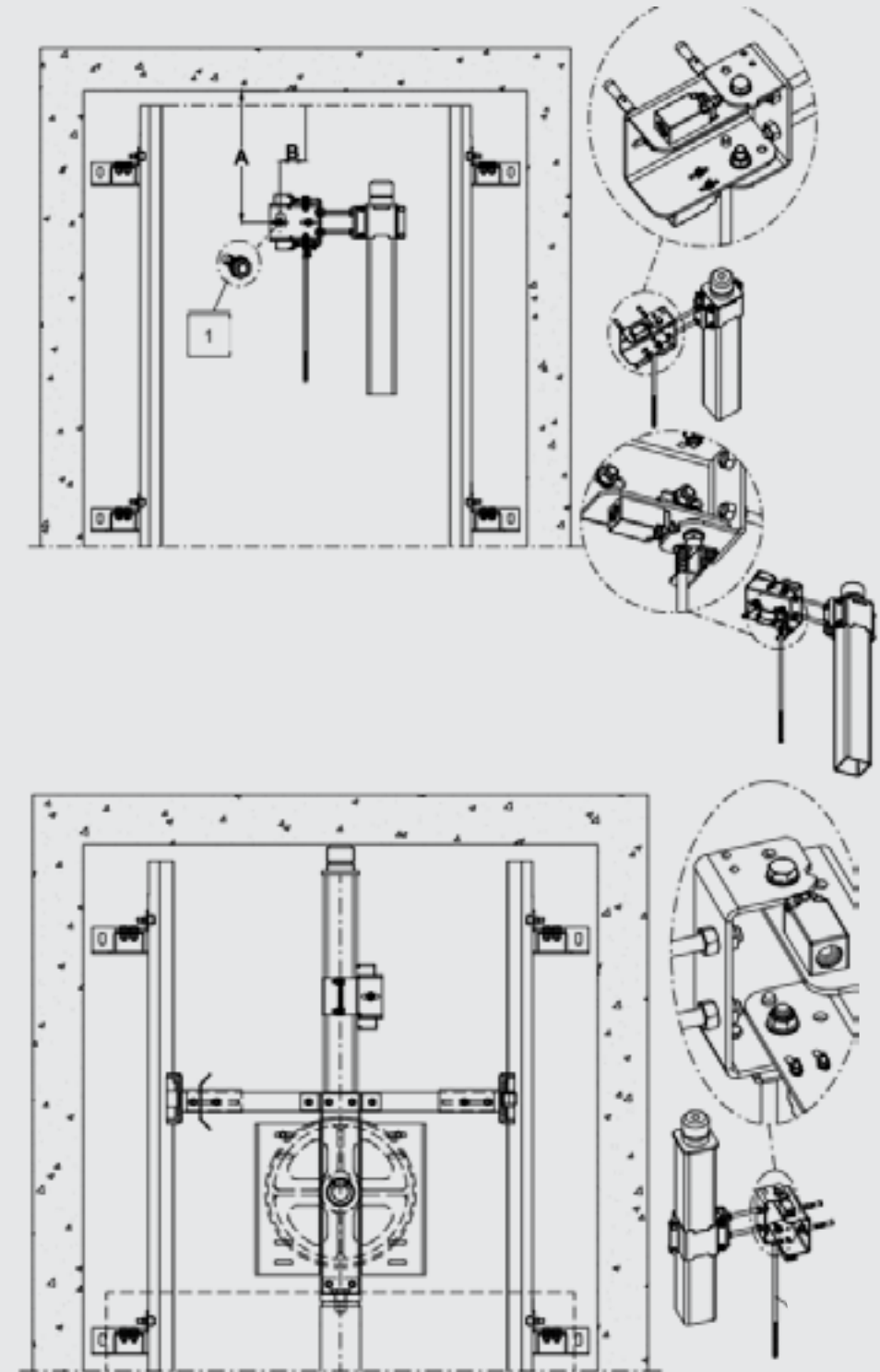



# MOD KITS

## Traction 81-21

### SECONDARY DOOR CONTACT

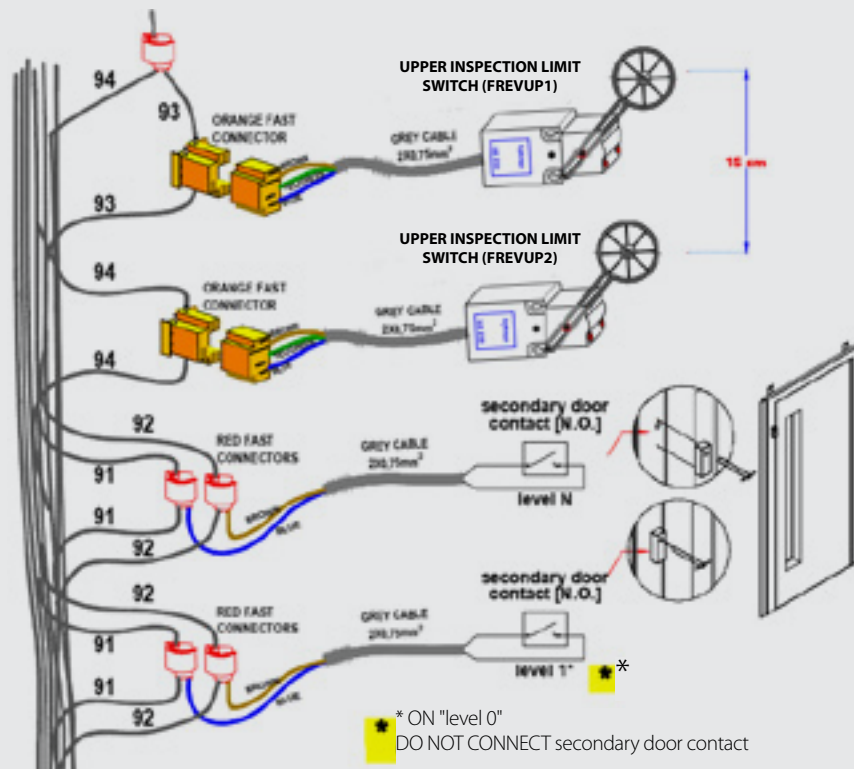

Shaft entrance monitoring contacts on landing doors. We add secondary door locks - bi stable contacts- that inform the controller whenever the triangle key of landing door is manually used. In this case, special circuit in the controller temporary blocks the normal use of the lift. A manual reset is necessary to return the lift in normal operation.

### FOLDABLE BALUSTRATE

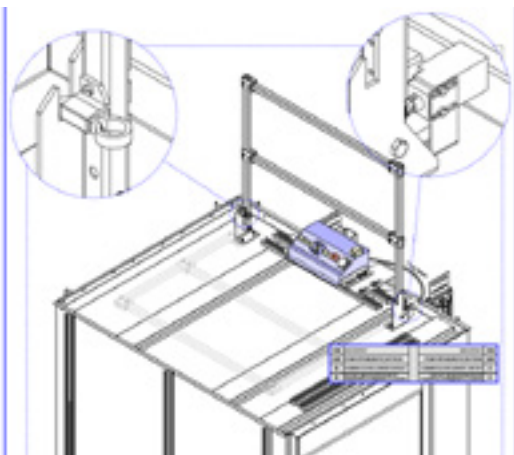

A foldable balustrade protects people from falling in shaft while working on top of the cabin. It is used in low headroom .

### POSITIONS OF THE TELESCOPIC BAR

1. Telescopic bar extended  
When the Telescopic bar is extended, the safety circuit is broken and the lift enters INSPECTION MODE. If the lift technician turns the inspection switch to the 'INS' position, the car can be moved.
2. Telescopic bar shrink  
When the Telescopic bar is shrink the lift is forbidden to enter in inspection mode [ in order to protect the lift- technician].

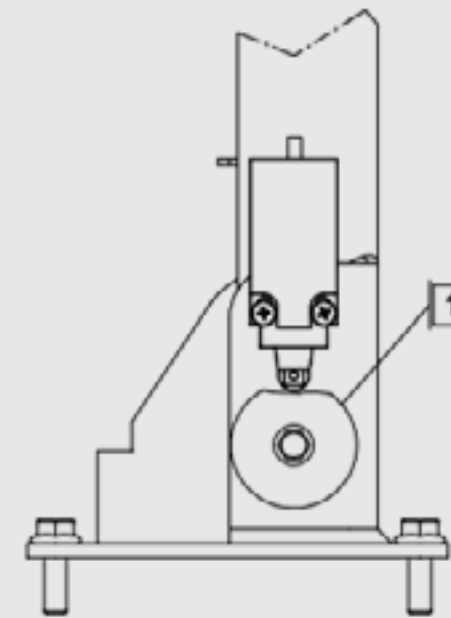

**BARI**  
Balustrade Inspection  
Position Switch

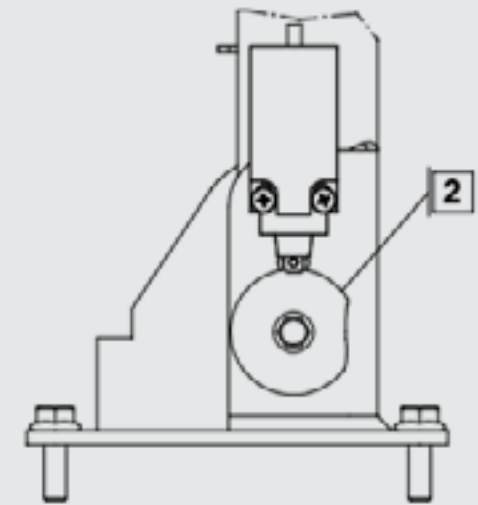

**BARN**  
Balustrade Normal  
Position Switch

a) Rise up the balustrade and set it to service operating position.

b) Put up each locker hinge (1) to unlock the balustrade and set it to the normal operating position.

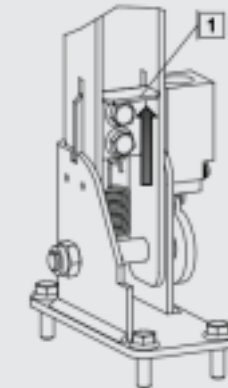
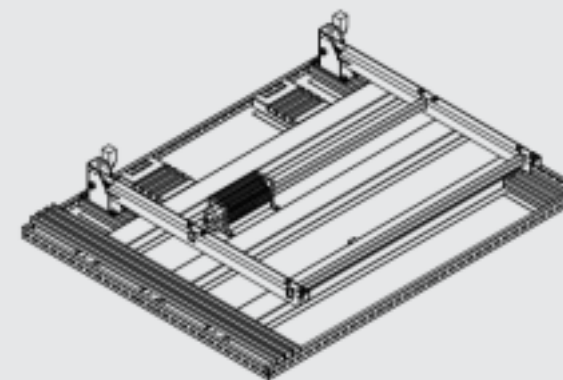



## MOD KITS

# Traction EN81-21

Mechanical travel limitation is used in case of reduced headroom and pit.

- A beam placed under the car sling in order to create a protected area in the pit
- A beam placed under the counterweight in order to create a protected area on top of the cabin

## MOD KITS

# Wrapped Type Car Apron WA175

Apron is important on cabin door. It prevents people from falling in the shaft when the lift stay over the floor with the doors opened (manual evacuation).

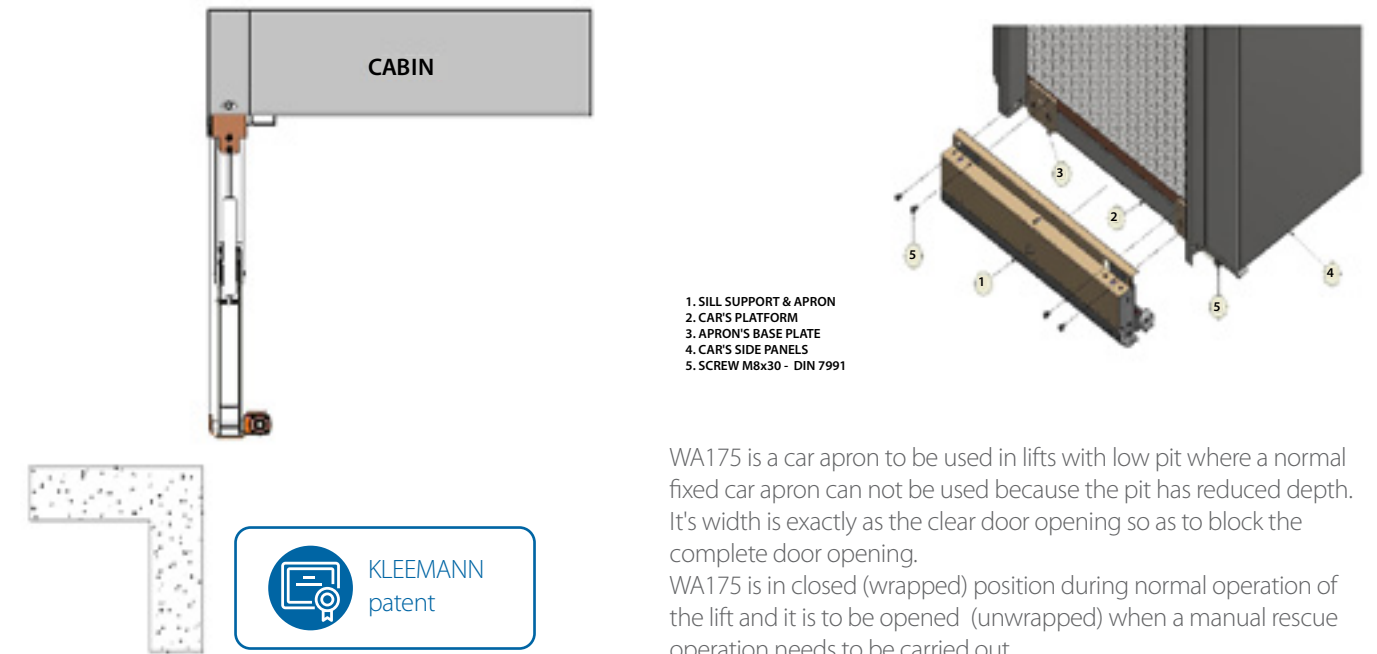
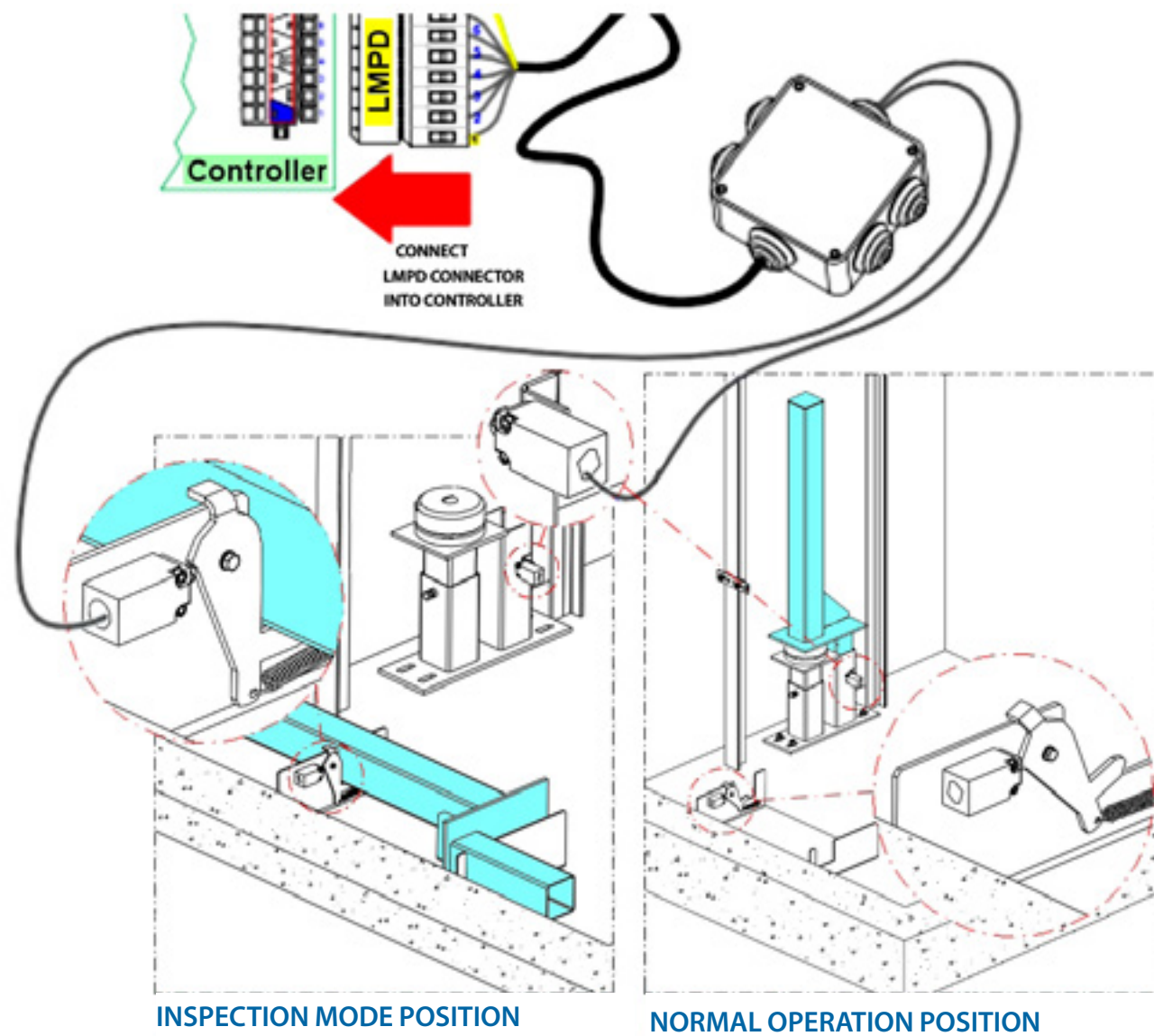

### MANUAL EXTENSION OF THE APRON

WA175 is a car apron to be used in lifts with low pit where a normal fixed car apron can not be used because the pit has reduced depth. It's width is exactly as the clear door opening so as to block the complete door opening. WA175 is in closed (wrapped) position during normal operation of the lift and it is to be opened (unwrapped) when a manual rescue operation needs to be carried out.

The fixed part of the apron in closed position is 175mm.

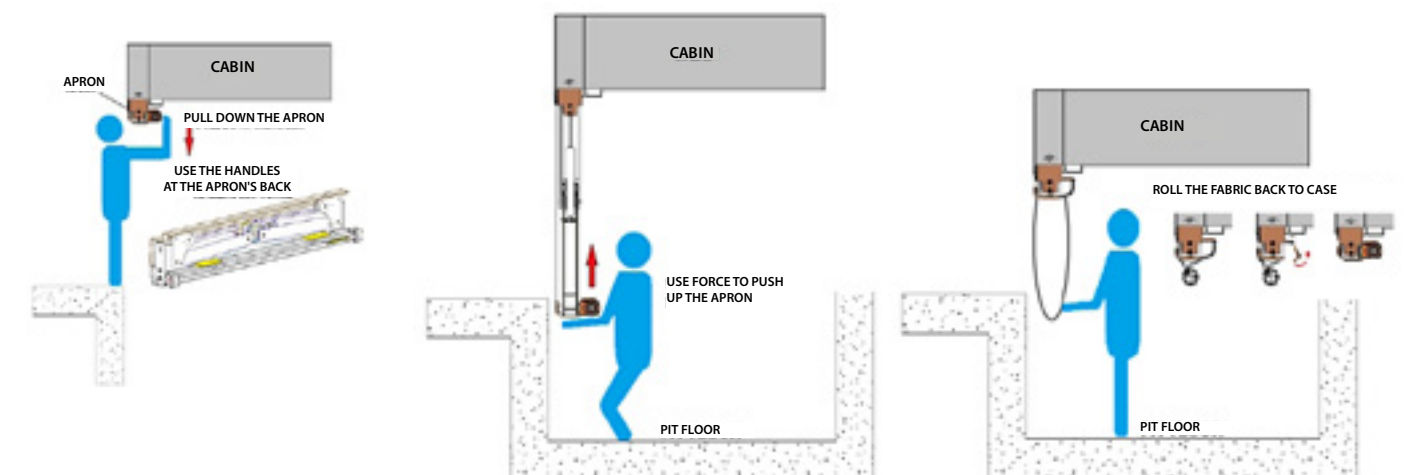

# Magic mirror

## THE MAGIC MIRROR

Is an LCD display, which is functioning as a normal display while it is activated and as a full mirror while it is deactivated. The surface glass/mirror is constructed to be combined with the LCD display and it complies with the necessary surface, hardness and tension requirements.

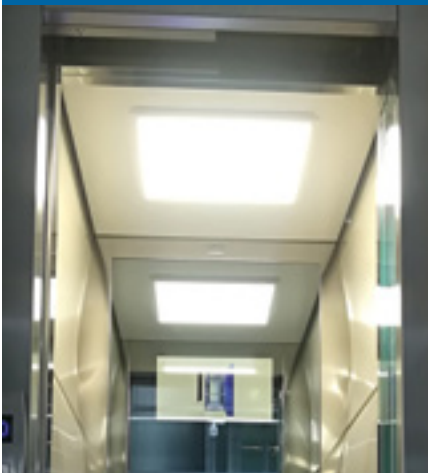

The position of the display area within the glass/mirror surface is freely selectable. It is only limited by the display, which has to be installed on the rear side of the glass. So, the factors that have to be considered are both the size of the image area according to the available LCD display sizes and the dimensions of the display external casing.

# Virtual Window



Virtual Window winGage by DigiGage is one of the world's first immersive architecture & experience design elevator products. The display adapts the viewer's point of view in real time, according to the elevator's movement.

With no integration or connectivity to the elevator's internal system, the patent pending Virtual Window software detects the movement of the elevator car - so it recognizes whether it is stationary or moving, its direction, speed and location. This analysis is translated to the movement of the display's content. For example, when the elevator moves upwards and the viewer's point of view should go upwards as well, the display view on the screen changes (e.g. floor-level objects stay down at floor level) as would occur if there was a real window in the elevator. This synchronizes the passenger's movement perception with their view - just like in a real transparent elevator. It doesn't stop there, though - certain content objects behave differently than others by escorting the window as the viewer is moving. For example, in an ocean world that is simulated by an elevator, a dolphin will follow the car while the reef stays at its initial position.

## EXTRA FEATURES:

- Floor numbering and floor signage
- Real-Time news and weather
- Building Messaging
- Social Media feature (facebook, twitter etc)





# MODERNIZATION SOLUTIONS

## Index

Index

### Symbols

- 2 STAGE TELESCOPIC CYLINDER **45**
- 3 STAGE TELESCOPIC CYLINDER **45**
- KIT EN81-21 Hydraulic **89**
- KIT EN81-21 TR **89**

### A

- A3 UCM **90**
- AKC BES
- BLUE LINE XX\* **70**
- AKC BES L
- XX\* **70**
- AKC HB XX\* **70**
- AKC-SM-BA
- BLUE LINE XX\* **71**
- AKL 001 **72**
- AKL 002 **72**
- AKL 003 **72**
- AKL 005 **72**
- AKL 055 **72**
- AKL 057 **72**
- AKL 101 **72**
- AKL 102 **72**
- AKL 103 **72**
- AKL 241 **72**
- AKL 242 **72**
- All in one ( MRL - UCONTROL ) **7**
- Artificial Granites **66**
- Automatic doors **54**

### B

- B37Q **73**
- B37R **73**
- Blue tag card **74**
- Box Lift **50**

### C

- Cabin Frame **45**
- CARD READER **74**
- Car Operating Panels & Indicators **70**
- Ceilings **66**
- Chemical mask
- FFP2 SL-VO **87**
- Combination wrench
- SW36 – SW46 **82**
- Counterweight Frame **38**
- Cut protection Gloves
- EURO CUT 3 P300 **84**
- CWF16 / CWF32 **38**

### D

- DITEC SOLUTION **69**
- DKC
- (DOT) Display **71**
- DKC
- (TFT Display) **71**
- Double box controller cabinet
- (MR OPTION) **7**
- Double Wrench
- SW42 – SW46 **82**
- Dust mask
- FFP1 **87**

### E

- Earplugs **87**
- ECN/ERN 1300 series **20**
- Eltra (Model EH88 PE) **24**
- EN 81-21 **91**
- Evac 3C **16**

### F

- Fall Arrest system **87**
- Floors **68**
- Folding / BUS type doors **60**
- FPY-1000 BLUE LINE **71**

- FTL001 slim **73**
- FTL 001
- Stainless Steel **69**
- FTL002 slim **73**
- FTL 002
- Stainless Steel **69**
- FTL101 slim **73**
- FTL 101
- Stainless Steel **73**
- FTL102 slim **73**
- Fuji Frenic LM2A **12**
- FTHL Slim **73**

### G

- Gas welding glasses **85**
- Genius 20 **5**
- Gloves for general use
- NITRIFIT Nr 10 **84**
- Gloves for general use
- Perfect Poly Black **84**
- Gloves for general use
- PU White **84**
- Guide rails **78**

### H

- Handrails **67**
- Head flashlight **86**
- Hearing protection
- Hearline MAX 200 **87**
- H40Q **73**
- Heidenhain ( Model ECN 1313 ) **22**
- Hyper Frame **32**
- HALO SL621 **73**
- HALO SL630 **73**
- HALO SC600 **71**
- HALO SC500 **51**
- HALO SH600 **73**
- HYDRO WWF **42**

### K

- K37 keyswitch **73**
- KEYSWITCH MT42 **75**
- KIT A3.1 **90**
- KIT A3.2 **90**
- KIT A3.3 **90**
- KLH42Q **73**
- KLH42R **73**
- Knee pads **87**

### L

- Landing Operating Panels **72**
- LICA (Model : C80 ) **25**

### M

- Machine base **30**
- Machines **28**
- Mask Chimilux **85**
- MRL DOORFRAME CONTROLLER CABINET (NARROW BOX) **6**
- MRL SCAN CONTROLLER CABINET (NARROW BOX ) **6**
- MT42 **73**
- Magic mirror **100**

### N

- Nemicon (Model SBH 1024 - 2T-30-050-00) **24**
- New Cabin Door PAIRED
- TO Old Landing Door **60**

### O

- Oil cooler **48**

### P

- Personal Protective Equipment (PPE) **8284**
- Power Unit **44**
- Protection glasses
- Open type ECOLUX **85**
- Protection glasses
- Open type VISILUX **85**

- P95-902 **73**

### R

- RAM **46**
- Ram clamp **83**
- Ram Head Extractor **83**
- Ram Head Inserter **83**
- RED – E **14**
- Reduced Headroom
- Mechanical Safety device (Hydraulic) **92**
- Retrofit Kit for shaft encoder **17**

- Ring Wrench

- SW55 **83**

- RT42 Class1 **71**

- Rope Gripper **33**

- RT42 **73**

- Rubbers **66**

### S

- Safety helmet OPAL **87**
- Safety shoes **86**
- Safety shoes
- S3 TIBER NAVY/BLUE **86**
- SBFR1 **30**
- SBFR2 **30**
- SECRET CODE **75**
- Semiautomatic / Hinged doors **58**
- Special Dimensions controller cabinet ALL IN ONE ( MR OPTION ) **7**
- Special Door Solutions **62**
- Standard controller cabinet
- ALL IN ONE ( MR OPTION ) **7**
- Standard MRL - 2 box controller **7**

### T

- Tapajuntas **60**
- TLCF 13-21 **36**
- TLCF 43 - 56 **37**
- TLCWF10 **39**

- TLCWF16 **39**
- TLCWF32 **39**
- Tools **82**
- Traction 81-21 **96**
- Traction Cabin Frame **36**
- Traction EN81-21 **98**
- TRANSCIVER **75**
- TRANSPONDER ES\_MEGA COMPLETE **72**

### V

- VINYL **69**
- Virtual Window **101**

### W

- Wachendorf (Model WDG 115) **25**
- WachendorfWDGAS58B **20**
- Welding Gloves **85**
- Welding Mask
- (VELDO ) WURTH **86**
- working waist
- protection belt **85**
- Work vest **87**
- WPY 910 VL **73**
- Wrapped Type Car Apron WA175 **99**

### Z

- Zetadyn 4CA **10**
- Zetadyn ZADYN4C 040-074 **11**
- Ziehl Abegg **18**

Contact us at  
[modernisation@kleemannlifts.com](mailto:modernisation@kleemannlifts.com)

---

[kleemannlifts.com](https://www.kleemannlifts.com)

**KLEEMANN HELLAS SA**  
Kilkis Industrial Area  
P.O. BOX 25, Kilkis, 611 00 - Greece  
G.E.M.I. 14486435000

While every effort has been to ensure the accuracy of the information in this brochure, KLEEMANN assumes no responsibility for omissions or typographical errors. Images are for demonstration purposes only. They are not suitable for construction/building purposes, nor feasibility studies.

Copyright © KLEEMANN 2026

