



KLEEMANN

Your 1st Choice in Lifts

Unveiling the new generation of KLEEMANN traction passenger MRL Lifts



NEW GENERATION OF KLEEMANN TRACTION MRL LIFTS

Design of a complete range of passenger lifts with **competitive price, reduced space requirements and faster installation time** based on the following design pillars:



REDUCED TOTAL COST OF OWNERSHIP

Through optimizations
in Design, Production,
Packing, Installation

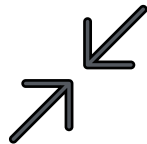

SPACE

Space efficiency and
competitive shaft
dimensions
commercially
optimizing space

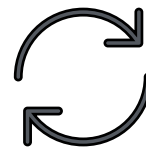

GREEN

Focus on energy
efficiency, eco-design,
reuse and recycling of
components elevating
your property's value



DIGITAL

IoT and smart
technologies.
Connectivity and
remote control via
apps



KLEEMANN City

ADVANTAGES

More usable building space

Reclaim up to **3% floor area** per lift with City design commercially optimizing space

Green & sustainable

City eco-friendly design & sustainable packaging enhance building sustainability, environmental performance, and elevate your property's value. **No welding & no painting.** Option for **Regen drive** available

Hassle-free installation

With engineering upgrades and scaffoldless methods, City can be installed in significantly less time compared to Atlas Basic. Experience reduced installation time, up to **25%** compared to previous model

Digital Solutions

City is compatible and offered with all available KLEEMANN Digital tools, **KLEEMANN Live** and Smart functions. Additionally, all of City editions are available via **portal** for orders & offers. **BIM** upon request



REDUCED SHAFT DEMANDS

Now, accommodate a 1100mm cabin width within a 1550mm shaft, reduced from 1600mm.

Also, achieve a 900mm pit and 3300mm headroom according to 81.20 regulations simultaneously.

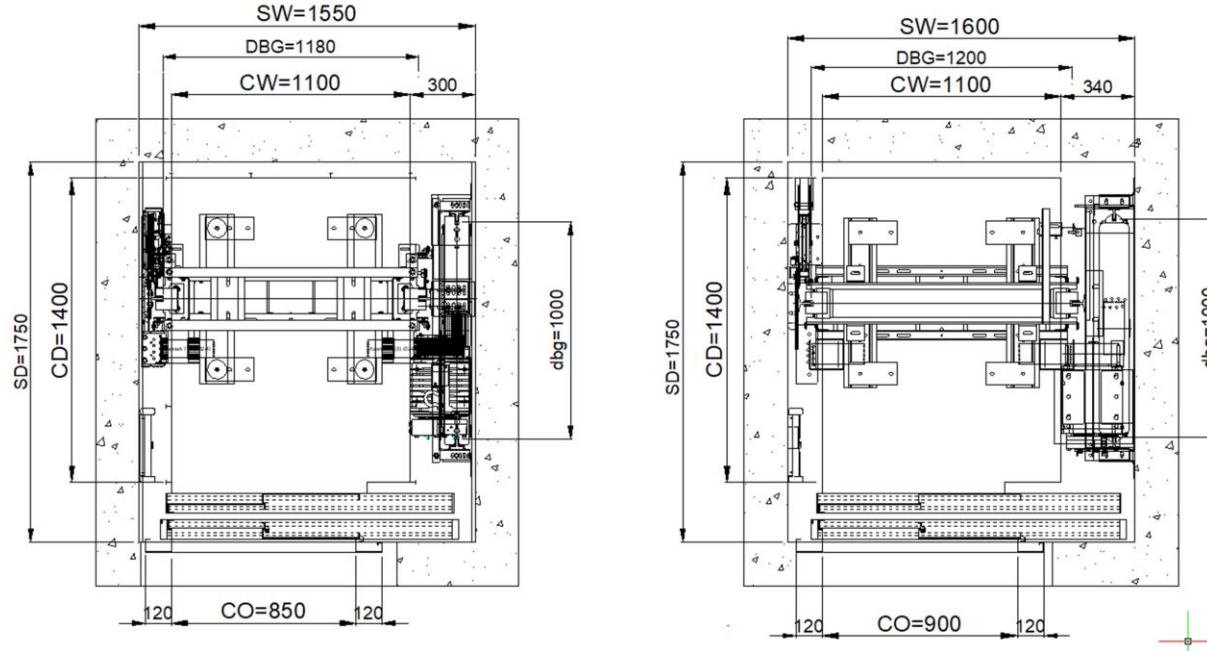

	Atlas Basic	City 100	City 300
Minimum Shaft Width	SW-CW=500	SW-CW=450	SW-CW=450
EN 81.20 Headroom	3400 mm	3300 mm	3300 mm
EN 81.20 PIT	1050 mm	1000 mm	900 mm



KLEEMANN City

REDUCED SHAFT DEMANDS

ERSxK KLEEMANN machine
exclusive for KLEEMANN

- ✓ D200 Traction Sheave for steel wire ropes
- ✓ Reduced weight: 630kg-> 20kg less, 1050kg-> 75 kg less
- ✓ Higher efficiency: plus ~1%
- ✓ Reduced noise levels-> 4%



Controller Cabinets

- ✓ Fully redesigned for minimal size (-40% Volume inside the shaft)
- ✓ Optimized electronics layout to maximize available working space on car top

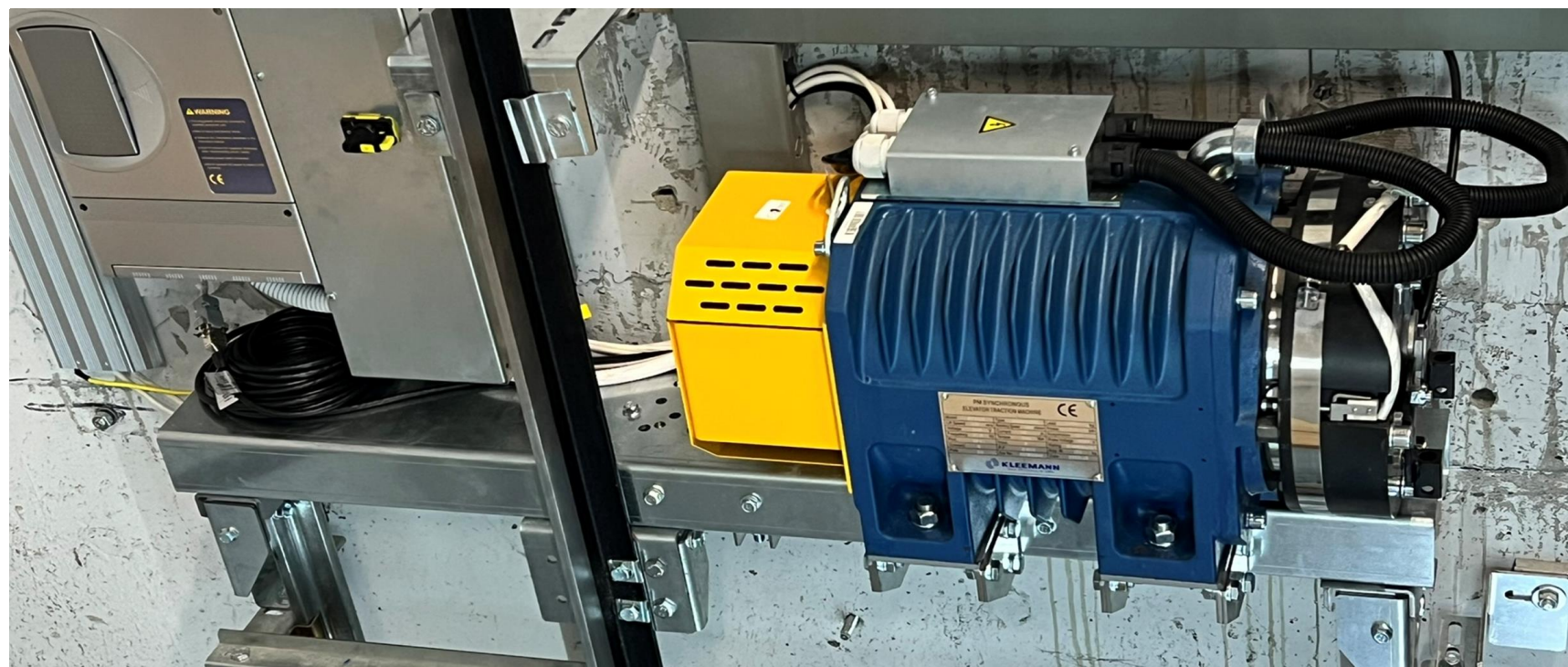



REDUCED INSTALLATION TIME UP TO 25%

- ① Support only on guide rails, not at walls
- ② Installation of frames requires fixing elements fewer than 70 flanged nuts and bolts
- ③ Reduced installation time due to wider tolerances on brackets and easy alignment due to design
- ④ Total weight reduction ~395Kg

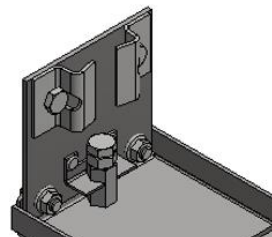
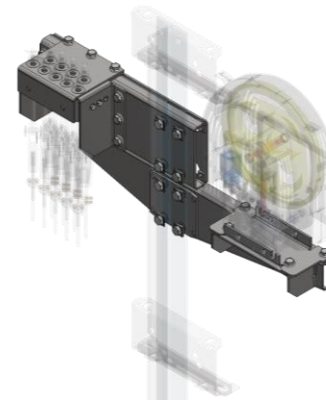



KLEEMANN City

GREEN & SUSTAINABLE LIFECYCLE INTEGRATION



Certifications & Documentations

City earns the highest evaluations with ISO 25745-2, VDI 4707-1, LEED and BREEM, a testament to superior energy efficiency and environmental commitment.

EPD available by Q4/2024



Reduced CO2 Emissions

Due to lighter packaging and new design, a standard City model is lighter than previous models, resulting in fuel savings during transportation to the construction site and occupies less space when packaged



Environmentally friendly materials

City is made from environmentally friendly materials, with no welding, and no painting, and avoiding hazardous materials



KLEEMANN City

GREEN & SUSTAINABLE LIFECYCLE INTEGRATION

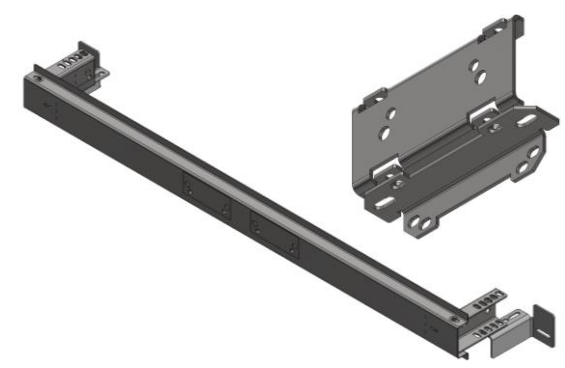
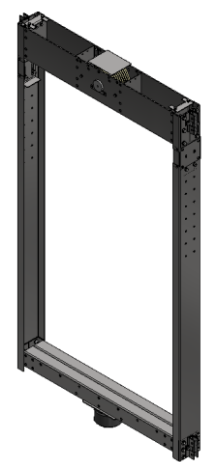

NO WELDING



NO PAINTING



MAXIMUM THICKNESS



DIGITAL
SOLUTIONS

KLEEMANN LIVE

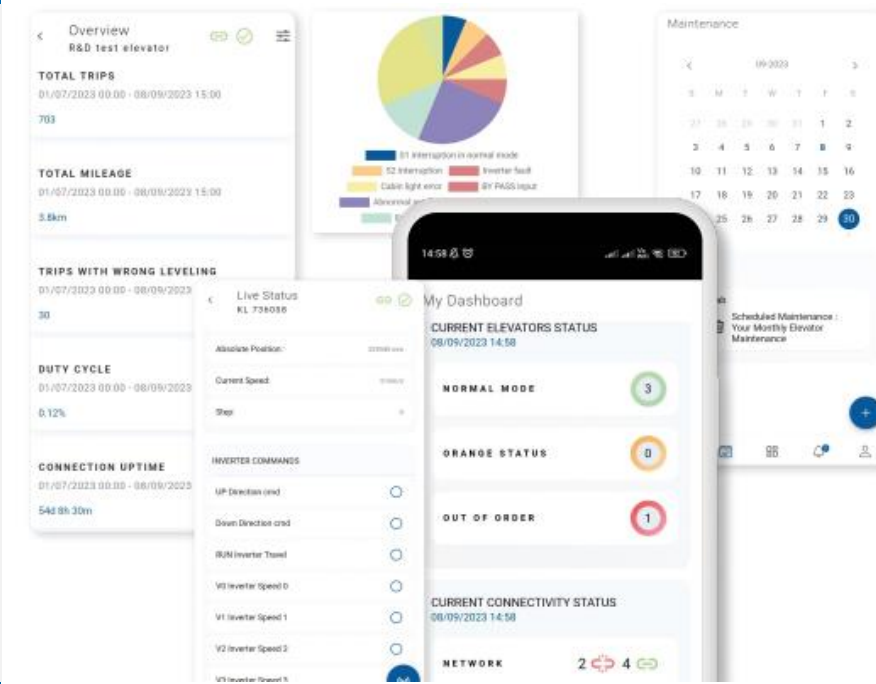

Welcome to KLEEMANN Portal

KLEEMANN Portal has been designed and developed with our customers' needs in mind.

[PROCEED](#)

[LOG IN AS KLEEMANN STAFF](#)

IoT New Functions

- ✓ KLEEMANN LIVE
 - Lift door function monitoring
 - Genius20 Remote Error Reset
 - SIM Data usage
- ✓ KLEEMANN Safety Line
 - KLEEMANN Safety Line Remote End Of Alarm

Mobile Apps

- | | |
|--|--|
| <ul style="list-style-type: none"> ✓ Lift Control Pro
For lift companies ➤ Android & iOS ➤ Supports all KLEEMANN live web functions ➤ Push notifications | <ul style="list-style-type: none"> ✓ Lift Control
For lift owners ➤ Android & iOS ➤ Monitoring elevators ➤ Remote call elevators ➤ Ticketing system for support ➤ Calendar with events ➤ Documents management |
|--|--|

Portal ready

- Offer in 5'
- Drawings in 10'
- Online Order
- Auto Correction
- Shaft Priority Option
- Increased options compared to Atlas



KLEEMANN City

UPGRADES

PURITY CABIN IMPROVEMENTS

75% of orders in 2023 through Portal include
Purity cabin

- Platform redesign, Galvanized, No welding and less weight for the installer. No need for floor disassembly for side change in purity S
- No Balustrade for standard shaft dimensions
- Rubber pads connect cabin to frame on top, not just the bottom, minimizing vibrations
- New fixed apron with less weight, new option fixed apron for 900mm Pit according EN 81.20 without electric contact
- One hour less installation time
- Purity E (Engraved) and mirror Full Width-Full Height



KLEEMANN City

UPGRADES

CAR TOP CONTROL IMPROVEMENTS

- Car top control embedded in upper beam
- Clear roof top working area
- Standardized position for all devices
- Less cables
- Faster installation time



P R O D U C T
R A N G E

ADVANTAGES



VALUE-DRIVEN ENGINEERING

Precisely constructed to endure, it lowers total ownership costs by focusing on key performance features, ensuring your property benefits from both affordability and reliability.



ECO-FRIENDLY DESIGN

It uses no welding or painting and also requires less energy to operate than a heavier MRL elevator. Consequently, it enhances the building's green credentials, lowers its carbon footprint, and boosts the whole value of the construction.



DIGITAL CONNECTIVITY

Merges the power of cutting-edge digital tools like KLEEMANN Live and Lift Control mobile apps. Take advantage of digital convenience by ordering your City 100 lift exclusively through our online KLEEMANN Portal.

KLEEMANN City



City 100

City 100 is the perfect combination of durability and functionality for residential and low-traffic buildings, featuring great design, digital connectivity, and value-driven engineering.





City 100

SPECIFICATIONS



Model	City 100
Rated Load (Kg)	320- 400- 450- 630- 1000
Max Travel (m)	21
Max Number of Stops	8
Max Speed (m/s)	1,0
Max persons	13
Max group size	8
Min Pit Depth (mm)	1000
Min Headroom (mm)	3300
Complies with	Lifts directive 2014/33/EU

ADVANTAGES



OPTIMIZED SHAFT EFFICIENCY

Reclaim up to 3% of floor area per lift with the commercially optimized space design of City 300. Enjoy reduced installation time and a guaranteed decrease in the total cost of ownership.



SUSTAINABLE DESIGN

Helps buildings reduce carbon emissions with its ecofriendly design and packaging while also boosting property value. With a lighter weight and a construction that uses no welding or painting, it is perfect for eco-conscious projects.



SUPERIOR ENGINEERING AND DESIGN

Engineered to meet the standards of a remarkably smooth ride with a minimal downtime, City 300 offers a variety of quality materials to encourage a mix and match approach and enable the process of creating the right look and feel.



DIGITAL CONNECTIVITY

Integrates advanced digital tools, including KLEEMANN Live and Lift Control Mobile apps. Embrace digital convenience by exclusively ordering City 300 online through our KLEEMANN Portal.



KLEEMANN City

City 300

City 300 lift solution by KLEEMANN offers unparalleled flexibility in design, allowing for a mix-and-match of materials, reduced shaft dimensions and green eco-design, for exceptional space and energy efficiency.





City 300

SPECIFICATIONS



Model	City 300
Rated Load (Kg)	320- 1050
Max Travel (m)	45
Max Number of Stops	16
Max Speed (m/s)	1,6
Max persons	13
Max group size	8
Min Pit Depth (mm)	900
Min Headroom (mm)	3300
Complies with	Lifts directive 2014/33/EU

ADVANTAGES



OPTIMIZED SHAFT EFFICIENCY

Reclaim up to 3% of floor area per lift with the commercially optimized space design of City 400. Enjoy reduced installation time and a guaranteed decrease in the total cost of ownership.



SUSTAINABLE DESIGN

Helps buildings reduce carbon emissions with its ecofriendly design and packaging while also boosting property value. With a lighter weight and a construction that uses no welding or painting, it is perfect for eco-conscious projects.



SUPERIOR ENGINEERING AND DESIGN

Engineered to meet the standards of a remarkably smooth ride with a minimal downtime, City 400 offers a variety of quality materials to encourage a mix and match approach and enable the process of creating the right look and feel.



DIGITAL CONNECTIVITY

Integrates advanced digital tools, including KLEEMANN Live and Lift Control Mobile apps. Embrace digital convenience by exclusively ordering City 400 online through our KLEEMANN Portal.



KLEEMANN City

City 400

City 400, equipped with the high-quality European Ziehl-Abegg machine, delivers superior strength, smooth rides, and added value to your project – making it the ideal choice for luxurious projects. Its integrated digital tools and versatile design make it a flexible solution, easily adaptable to the requirements of mid-rise and high-traffic commercial buildings with demanding specifications.





City 400

SPECIFICATIONS



Model	City 400
Rated Load (Kg)	630- 1050
Max Travel (m)	60
Max Number of Stops	17
Max Speed (m/s)	1,6
Max persons	14
Min Pit Depth (mm)	900
Min Headroom (mm)	3300
Complies with	Lifts directive 2014/33/EU



KLEEMANN
Your 1st Choice in Lifts

Thank you

KLEEMANN HELLAS SA
Kilkis Industrial Area
P.O. BOX 25, Kilkis, 611 00 - Greece
G.E.MI. 14486435000

www.kleemannlifts.com